

SUPER FUN PARK

fischertechnik 

ADVANCED



Inhalt
Contents
Contenu

Inhoud
Contenido
Conteúdo

Contenuto
Содержание
目录

Einzelteilübersicht / Spare parts list / Liste des pièces détachées / Onderdelenoverzicht / Lista da piezas / Resumo de peça individual /
Singoli componenti / Перечень деталей / 零件概览 1

Montagetipps / Tips for assembly / Tuyaux pour le montage / Montagetips / Consejos para el montaje / "Dicas" para montagem /
Consigli per il montaggio / Советы по сборке / 装配建议 2



Riesenrad / Ferris wheel / Grande roue / Reuzenrad / Noria /
Roda gigante / Ruota gigante / Чертово колесо / 巨型轮 4



Karussell / Carousel / Carrousel / Mallemolen / Tío vivo /
Carrocel / Giostra / Карусель / 转盘 13



Zentrifuge / Centrifuge Ride / Centrifuge / Centrifuge / Centrifuga /
Centrifuga / Centrifuga / Центрифуга / 离心机 20

Einzelteilübersicht
Spare parts list
Liste des pièces détachées

Onderdelenoverzicht
Lista da piezas
Resumo de peça individual

Singoli componenti
Перечень деталей
零件概览

	31 010 12 x		32 321 1 x		36 324 8 x		130 593 6 x
	31 011 24 x		32 850 6 x		36 443 1 x		132 223 16 x
	31 019 3 x		35 031 3 x		36 819 12 x		135 719 1 x
	31 022 1 x		35 051 12 x		36 977 1 x		136 775 1 x
	31 023 12 x		35 053 24 x		36 981 1 x		137 096 9V... 1 x
	31 058 3 x		35 059 12 x		37 237 51 x		139 645 2 x
	31 078 1 x		35 060 24 x		37 468 8 x		139 646 4 x
	31 082 1 x		35 061 12 x		37 527 1 x		139 647 8 x
	31 264 6 x		35 064 1 x		37 679 6 x		139 648 4 x
	31 330 6 x		35 065 12 x		38 411 12 x		
	31 336 2 x		35 066 6 x		38 531 24 x		
	31 337 2 x		35 073 24 x		38 538 10 x		
	31 667 24 x		35 806 2 x		38 542 3 x		
	31 674 24 x		35 945 3 x		68 535 2 x		
	31 981 8 x		36 294 24 x		116 252 20 x		
	31 982 13 x		36 323 130 x		127 471 3 x		
	32 064 10 x				127 472 9 x		

Montagetipps

Tips for assembly

Tuyaux pour le montage

Montagetips

Consejos para el montaje

"Dicas" para montagem

Consigli per il montaggio

Советы по сборке

装配建议

Kabel und Stecker
Plugs and cables
Fiches et des câbles

Stekkers en cables
Enchufes en cables
Cabos e contatos

Cavi e connettori
Провода и штекеры
电缆和插头

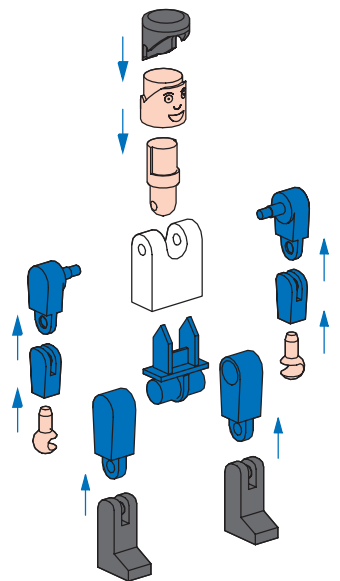
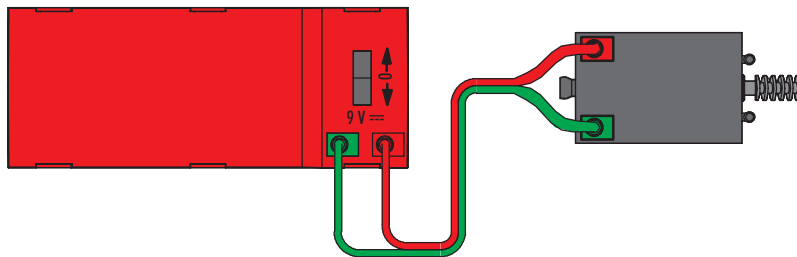
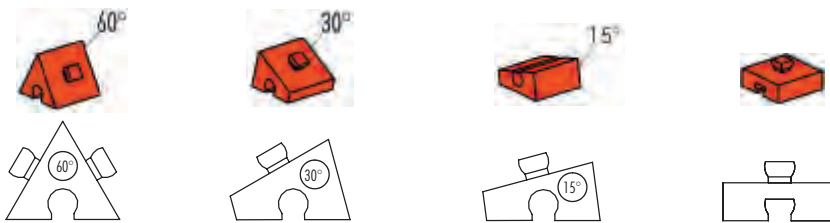
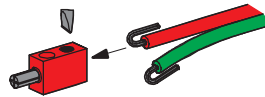
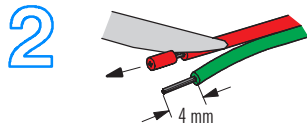

- Hinweise zum Umweltschutz**
Die elektrischen und elektronischen Bauteile dieses Baukastens (z. B. Motoren, Lampen, Sensoren) gehören nicht in den Hausmüll. Sie müssen am Ende ihrer Lebensdauer an einem Sammelpunkt für das Recycling von elektrischen und elektronischen Geräten abgegeben werden. Das Symbol auf dem Produkt, der Verpackung oder der Anleitung weist darauf hin.
- Instructions for Environmental Protection**
Do not put the electrical and electronic components of this construction kit such as motors, lights and sensors in the household waste. At the end of their service life, take them to a collection point for the recycling of electrical and electronic devices. The symbol on the product, packaging or the instructions shows this.
- Remarques de protection de l'environnement**
Les composants électriques et électroniques de ce coffret (par ex. moteurs, lampes, capteurs) ne doivent pas être jetés avec les ordures ménagères. Lorsqu'elles ne sont plus utilisables, il faut les remettre auprès d'un centre de collecte spécialisé dans le recyclage des appareils électriques et électroniques. Le symbole sur le produit, l'emballage ou la notice d'instructions le signale.
- Bescherming van het milieu**
De elektrische en elektronische onderdelen van deze module (bijv. motoren, lampen, sensoren) behoren niet bij het huisvuil. Aan het einde van hun levensduur moeten ze worden ingeleverd bij een verzamelplaats voor de recycling van elektrische en elektronische apparaten. Het symbool op het product, de verpakking of de gebruiksaanwijzing wijst je daar ook op.
- Notas con respecto a la protección del medio ambiente**
Los componentes eléctricos y electrónicos de esta unidad modular (p. ej. motores, lámparas, sensores) no han de tirarse a la basura casera. Al final de su vida útil tienen que ser entregados en un puesto colector para el reciclaje de aparatos eléctricos y electrónicos. El símbolo sobre el producto, el embalaje o las instrucciones lo señala.

- Instruções para a proteção do meio ambiente**
Os componentes elétricos e eletrônicos deste módulo (p.ex. motores, lâmpadas, sensores) não pertencem ao lixo doméstico. Eles devem ser entregues, no final da sua vida útil, num posto de coleta para a reciclagem de aparelhos elétricos e eletrônicos. O símbolo no produto, na embalagem ou no manual indica isto.
- Indicazioni sulla tutela ambientale**
I componenti elettrici ed elettronici di questa scatola di montaggio (ad es. motori, lampadine, sensori) non vanno smaltiti tra i rifiuti domestici. Alla fine della loro durata di utilizzo devono essere consegnati a un centro di raccolta adibito al riciclaggio di apparecchi elettrici ed elettronici. Ciò viene indicato dal simbolo che si trova sul prodotto, sull'imballo o sul manuale d'istruzioni.
- Указания по охране окружающей среды**
Электрические и электронные детали этого комплекта (датчики, электромоторы, лампочки и др.) нельзя выбрасывать с бытовым мусором. После того как они отслужат свой срок, их нужно сдать для переработки на сборный пункт электрических и электронных приборов. На это указывает знак на изделии, на упаковке или на инструкции.
- 有关环保的提示**
不得将本组件中的电气和电子部件(如电机, 灯泡, 传感器)当作家庭垃圾扔掉。等它们的使用寿命结束后, 应将它们送抵电气和电子器材回收站。产品、包装或说明书上的标记也说明这一规定。



Sicherheitshinweise Safety Information Consignes de sécurité

Veiligheidsrichtlijnen Indicaciones de seguridad Observações sobre segurança

Informazioni per la sicurezza Указания по технике безопасности 安全指南

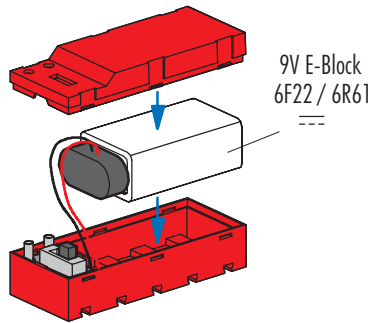

Batterie ist nicht Inhalt der Packung
Battery not included
Batterie non comprise
De batterij wordt niet meegeleverd
La batería no está incluida en el suministro
A bateria não é o conteúdo da embalagem
La batteria non è inclusa nella confezione
Батарея в комплект не входит
包装中不含电池

1 Batterie 9Volt-Block Alkaline oder 1 NiMH-Akku 9V

- Nicht wiederaufladbare Batterien dürfen nicht geladen werden
- Aufladbare Batterien dürfen nur von Erwachsenen geladen werden
- Aufladbare Batterien sind aus dem Batteriehalter herauszunehmen, bevor sie geladen werden.
- Batterien müssen mit der richtigen Polarität eingelegt werden.
- Leere Batterien müssen aus dem Spielzeug herausgenommen werden
- Die Anschlussklemmen dürfen nicht kurzgeschlossen werden.
- Verbrauchte Batterien dem Sondermüll zuführen.
- Drähte nicht in Steckdose einführen!
- Ladegerät regelmäßig auf Schäden überprüfen. Bei einem Schaden darf das Ladegerät bis zur vollständigen Reparatur nicht mehr verwendet werden.

9V rechargeable battery or 9 V alkaline dry cell

- Do not attempt to charge NON-rechargeable batteries.
- Rechargeable batteries are only to be charged by adults.
- Take rechargeable batteries out of the battery tray before charging them.
- Insert batteries with the correct polarity.
- Remove dead batteries from the toy.
- Do not short circuit the connecting terminals!
- Discard spent dry cells at special waste disposal centre.
- Do not insert the wires into an outlet!
- Regularly inspect battery charger for damage. If the battery charger has been damaged, it should not be used further until fully repaired.

pile 9V ou accu 9V

- Il est interdit de recharger des piles qui ne sont pas des accumulateurs
- Le chargement des accumulateurs doit toujours se faire par des adultes
- Retirer les accumulateurs du support de pile avant de les recharger.
- Veiller à la polarité correcte lors de la mise en place des piles.
- Retirer impérativement les piles ou accumulateurs vides du jouet.
- Il est interdit de court-circuiter les bornes de raccordement.
- Jeter les piles usagées dans un conteneur spécial réservé à cet effet.
- Ne pas introduire les fils dans une prise !
- Contrôlez régulièrement le chargeur en vue d'éventuelles détériorations
- En cas de détérioration, il est interdit d'utiliser le chargeur jusqu'à ce qu'il ait été intégralement réparé

alkaline batterij of oplaadbare batterij (9Volt)

- Niet-oplaadbare batterijen mogen niet worden opgeladen.
- Oplaadbare batterijen mogen uitsluitend door volwassenen worden opgeladen.
- Oplaadbare batterijen moeten uit de batterijhouder worden verwijderd, voordat deze worden opgeladen.
- De batterijen moeten met de juiste polariteit worden geplaatst.
- Lege batterijen moeten uit het speelgoed worden verwijderd.
- De aansluitklemmen mogen niet worden kortgesloten.
- Afleveren gebruikte batterijen bij het klein chemisch afval (KCA).
- Geen draden in de contactdoos steken!
- Laadtoestel regelmatig controleren op schade. Bij schade mag het laadtoestel niet meer gebruikt worden tot het volledig hersteld is.

pila alcalina bloque de 9 Voltios o acumulador NiMH- de 9 Voltios

- Las pilas no recargables no pueden ser cargadas
- Las pilas recargables sólo pueden ser cargadas por un adulto
- Las pilas recargables deben ser extraídas del compartimento de pilas antes de que sean cargadas.
- Las pilas deben ser colocadas con la polaridad correcta.
- Las pilas descargadas deben ser extraídas del juguete
- Los bornes de conexión no pueden ser puestos en cortocircuito.
- Retirar las baterías viejas, desechándolas en un depósito de basuras especiales.
- No introducir hilos en la toma de corriente!
- Comprobar con regularidad si el cargador presenta daños. En caso de presentar daños, el cargador no debe volver a ser utilizado hasta que esté completamente reparado.

Bateria alcalina de bloco de 9 V ou acumulador NiMH- de 9 V

- Pilhas não recarregáveis não devem ser novamente carregadas.
- Pilhas recarregáveis somente devem ser recarregadas por adultos.
- As pilhas recarregáveis devem ser retiradas do compartimento de pilhas antes de serem carregadas.
- As pilhas devem ser colocadas com a polaridade correta.
- As pilhas descarregadas devem ser retiradas do brinquedo.
- Os terminais de conexão não devem ser curto-circuitados.
- Eliminar as baterias esgotadas como desperdício perigoso
- Nunca introduzir fios na tomada!
- Verificar regularmente se o carregador apresenta danos. Em caso de dano, o carregador não deverá ser utilizado enquanto não estiver plenamente consertado.

1 batteria alcalina da 9 V o 1 batteria NiMH- ricaricabile da 9V

- Le batterie non ricaricabili non devono essere ricaricate
- Le batterie ricaricabili devono essere ricaricate da persone adulte
- Le batterie ricaricabili si devono estrarre dal supporto prima di ricaricarle.
- Le batterie si devono inserire rispettando la polarità.
- Tagliare le batterie dal giocattolo quando sono scariche
- I morsetti di allacciamento non devono essere cortocircuitati.
- Smaltire le batterie usate negli appositi contenitori per la raccolta differenziata.
- Non inserire i fili nella presa elettrica.
- Controllare periodicamente se il caricabatterie presenta dei danni. In caso di danni, il caricabatterie non deve più essere utilizzato fino alla riparazione.

1 алкалоидная батарейка на 9 В или 1 никель-кадмиевый аккумулятор, 9 В

- Не пытайтесь заряжать перезаряжаемые батарейки.
- Зарядку перезаряжаемых аккумуляторов разрешается выполнять только взрослым.
- Перед зарядкой перезаряжаемых аккумуляторов извлеките их из аккумуляторного отсека.
- При установке аккумуляторов на место соблюдайте полярность.
- Разряженные батарейки необходимо извлечь из игрушки.
- Не замыкайте накоротко соединительные клеммы.
- И использованные батареи утилизировать как спецотходы.
- Не вставляйте в розетку провода!
- Регулярно проверяйте зарядное устройство на отсутствие повреждений. При наличии повреждений использовать зарядное устройство до выполнения его полного ремонта не разрешается.

1个9V的碱性方电池或1个9V的NiMH-蓄电

- 不得给非充电电池充电
- 只允许由成年人给充电电池充电
- 在充电前必须将充电电池从电池夹中取出。
- 必须按照正负极正确放入电池。
- 必须从玩具中取出没有电的电池
- 接线柱不允许被短路。
- 用完了的电池应作为特种垃圾处理。
- 禁止将金属丝插入插座！
- 经常检查充电器是否有损坏情况。如果充电器有损，直到完全修好为止不可以再使用。

Alle Einzelteile, insbesondere bewegliche Teile sind falls notwendig zu warten und zu reinigen.

All components, especially moving parts, should be maintained and cleaned as necessary.

Toutes les pièces détachées et en particulier les pièces mobiles, sont, si nécessaire, à entretenir et à nettoyer.

Alle onderdelen, vooral de bewegende delen, kunnen, indien noodzakelijk, onderhouden en gereinigd worden.

Es necesario limpiar y mantener en buen estado todas las diferentes piezas - especialmente las piezas móviles.

Achtung

Verletzungsgefahr an Bauteilen mit funktionsbedingten scharfen Kanten und Spitzen!

Caution

Be careful not to hurt yourself on components with sharp or pointed edges!

Attention

Risque de blessure sur les éléments comportant des arêtes et o pointes vives indispensables au bon fonctionnement!

Let op

U kunt zich bezeren aan bouwstenen met scherpe randen of punten!

Attenzione

Esiste il pericolo di lesione con i pezzi di costruzione che hanno bordi e punte spigolosi necessari per la funzionalità del pezzo!

Caso necessário, todas as peças individuais, especialmente peças móveis, tem que ser submetidas à manutenção e ser limpadas.

Se necessario, tutti i singoli componenti, soprattutto le parti mobili, si devono eventualmente sottoporre a manutenzione e pulizia.

Все детали, особенно подвижные, требуют ухода и чистки.

必要时应保养和清洁所有零件，尤指运动部件。

Atenção

Perigo de ferimentos em peças componentes com cantos vivos e pontas obrigatórias para o funcionamento !

Attenzione

Pericolo di lesioni dovute a componenti con spigoli vivi e punte per motivi funzionali!

Будьте осторожны

Об острые края деталей и и наконечники можно порезаться!

注意

因功能需要而带有锋利的棱边和尖角的部件可能会带来受伤危险！



Riesenrad
 Ferris wheel
 Grande roue

Reuzenrad
 Noria
 Roda gigante

Ruota gigante
 Чертово колесо
 巨型轮

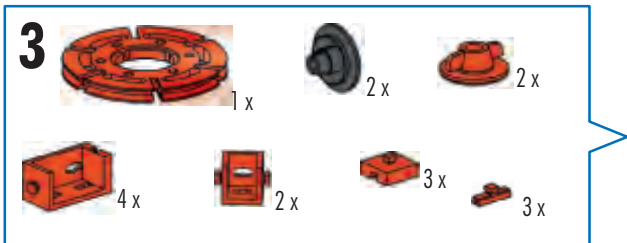
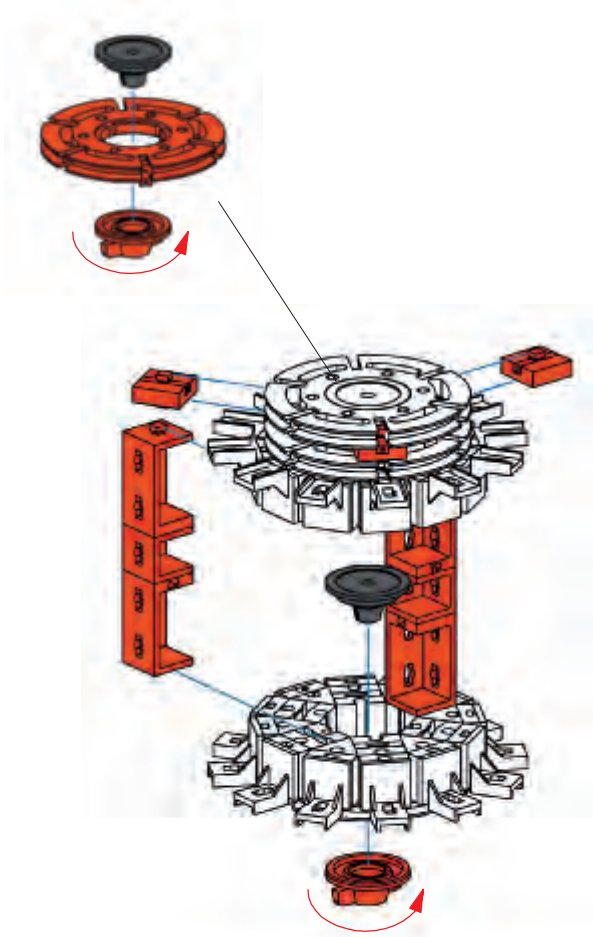
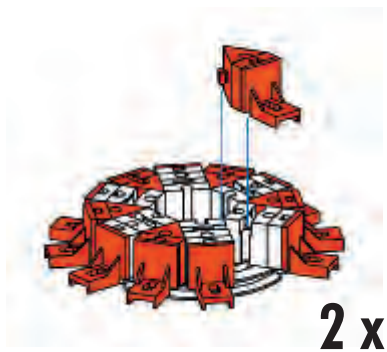
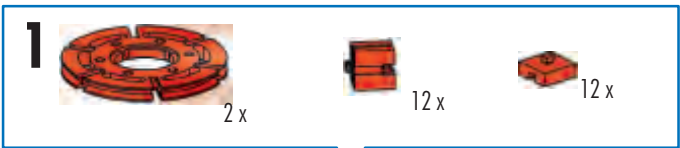

4

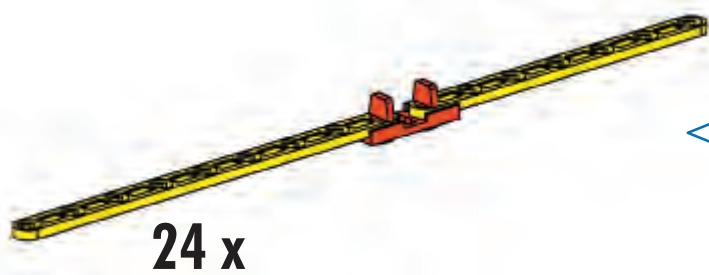
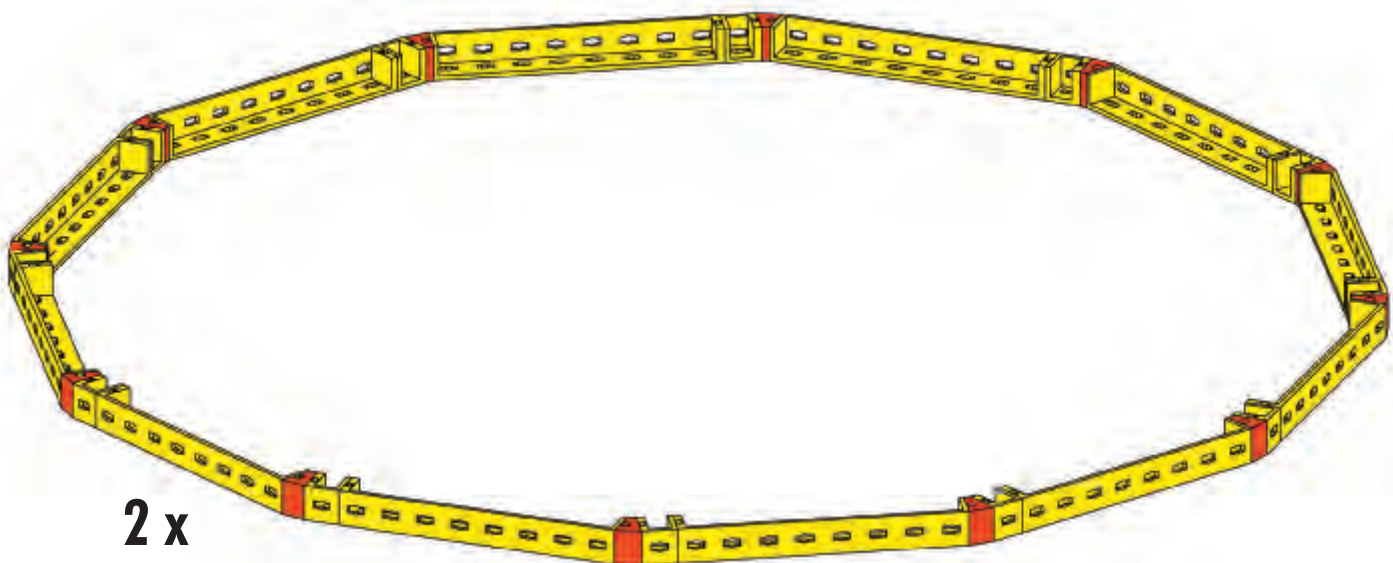
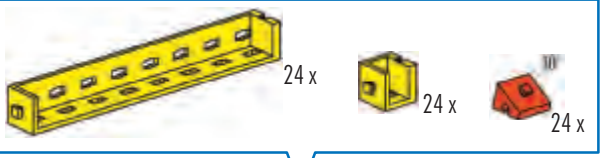

5

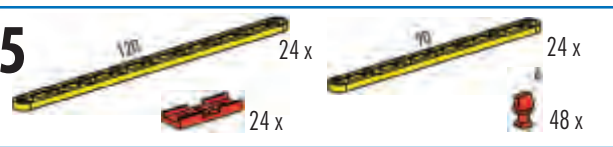

6



4

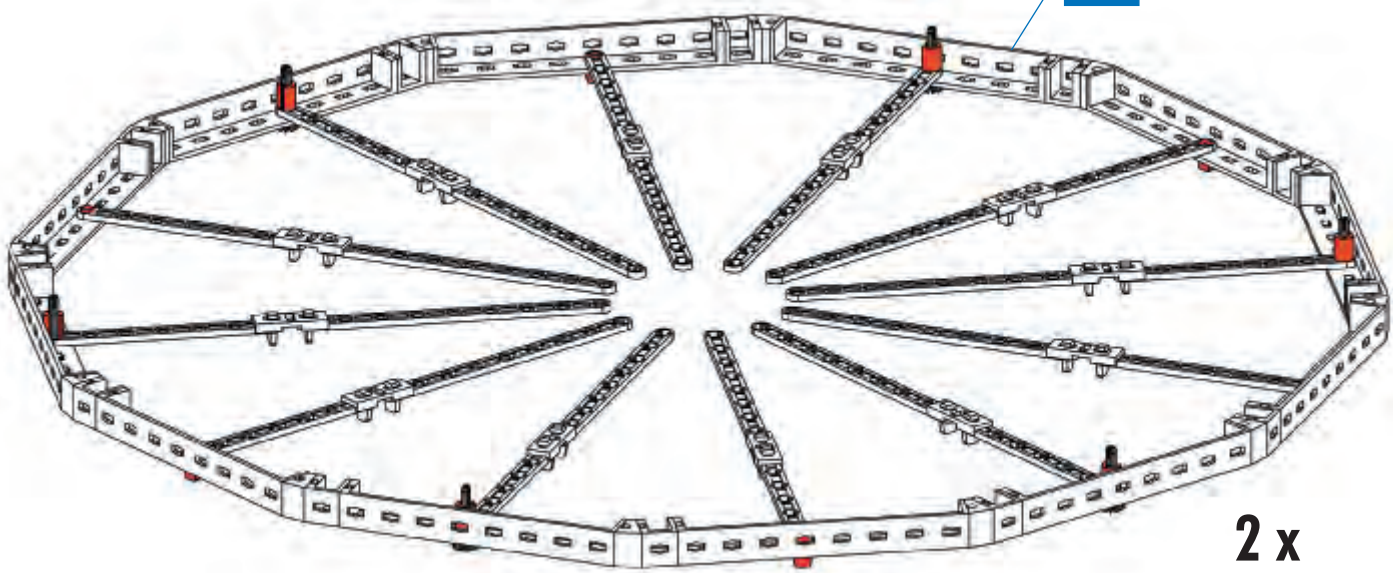

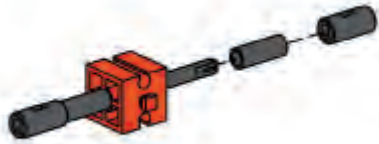

6 x

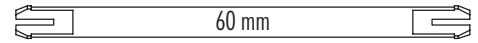

8 24 x

6

7

6

7

7

7

9

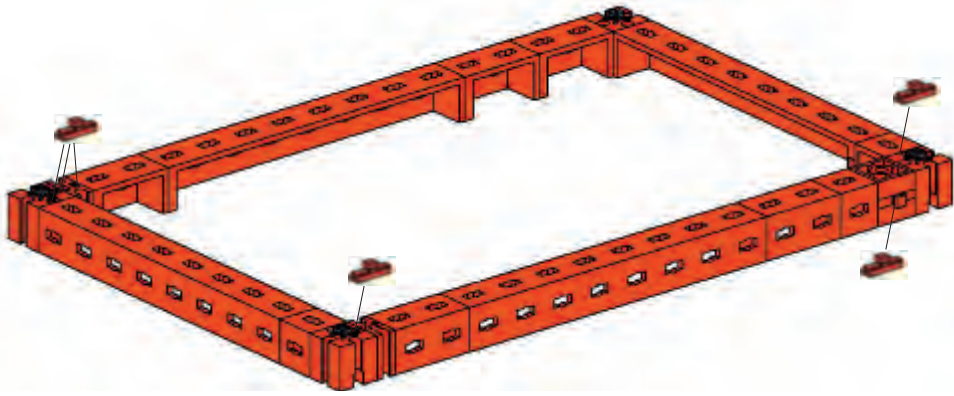
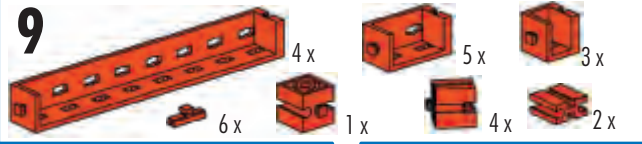

10

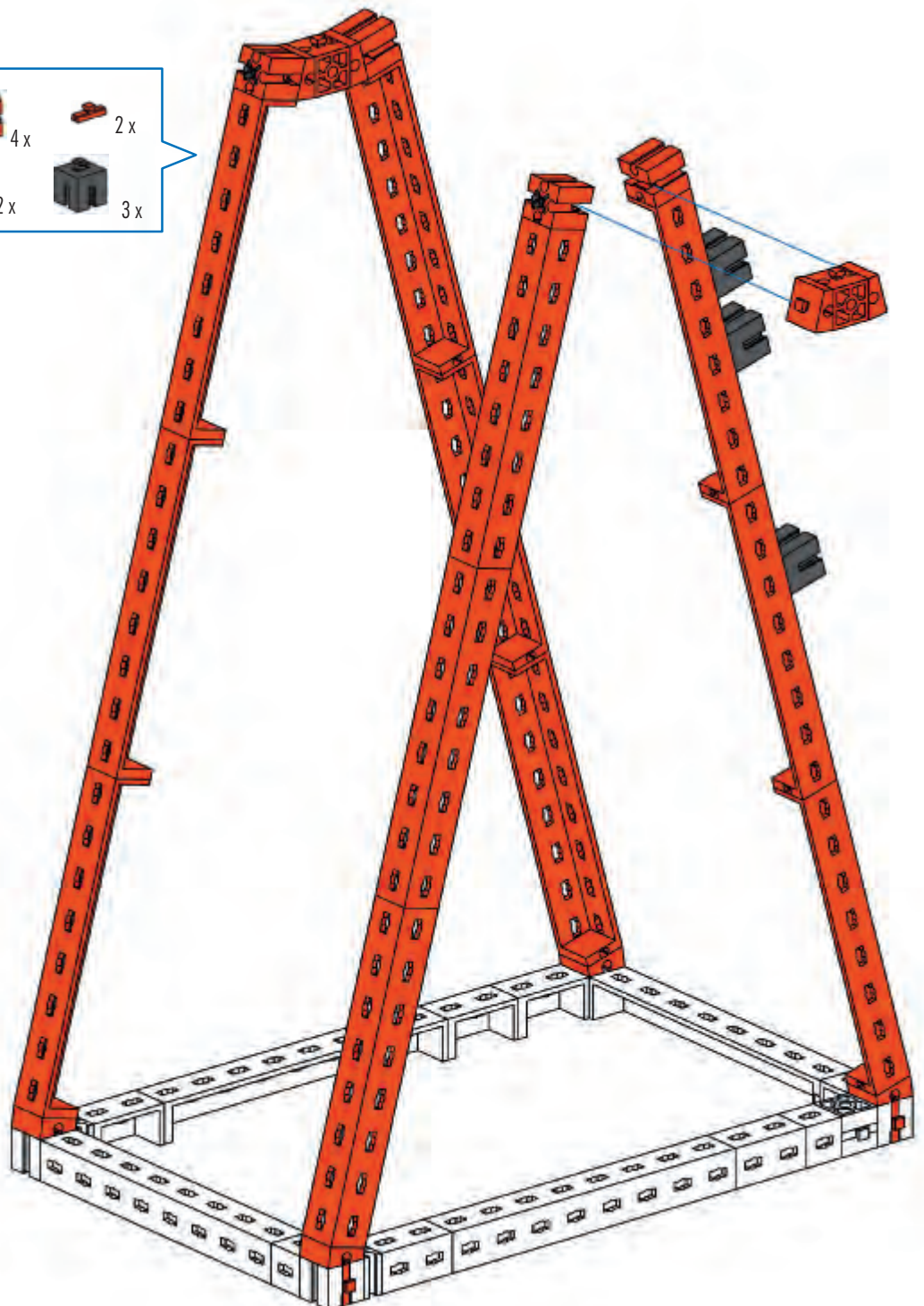
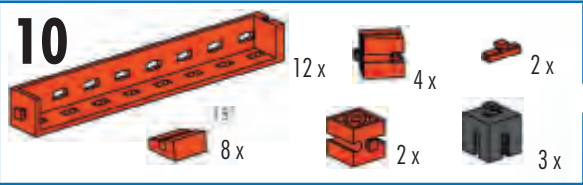

11

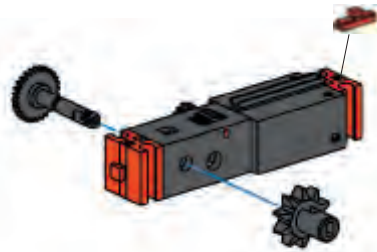

12

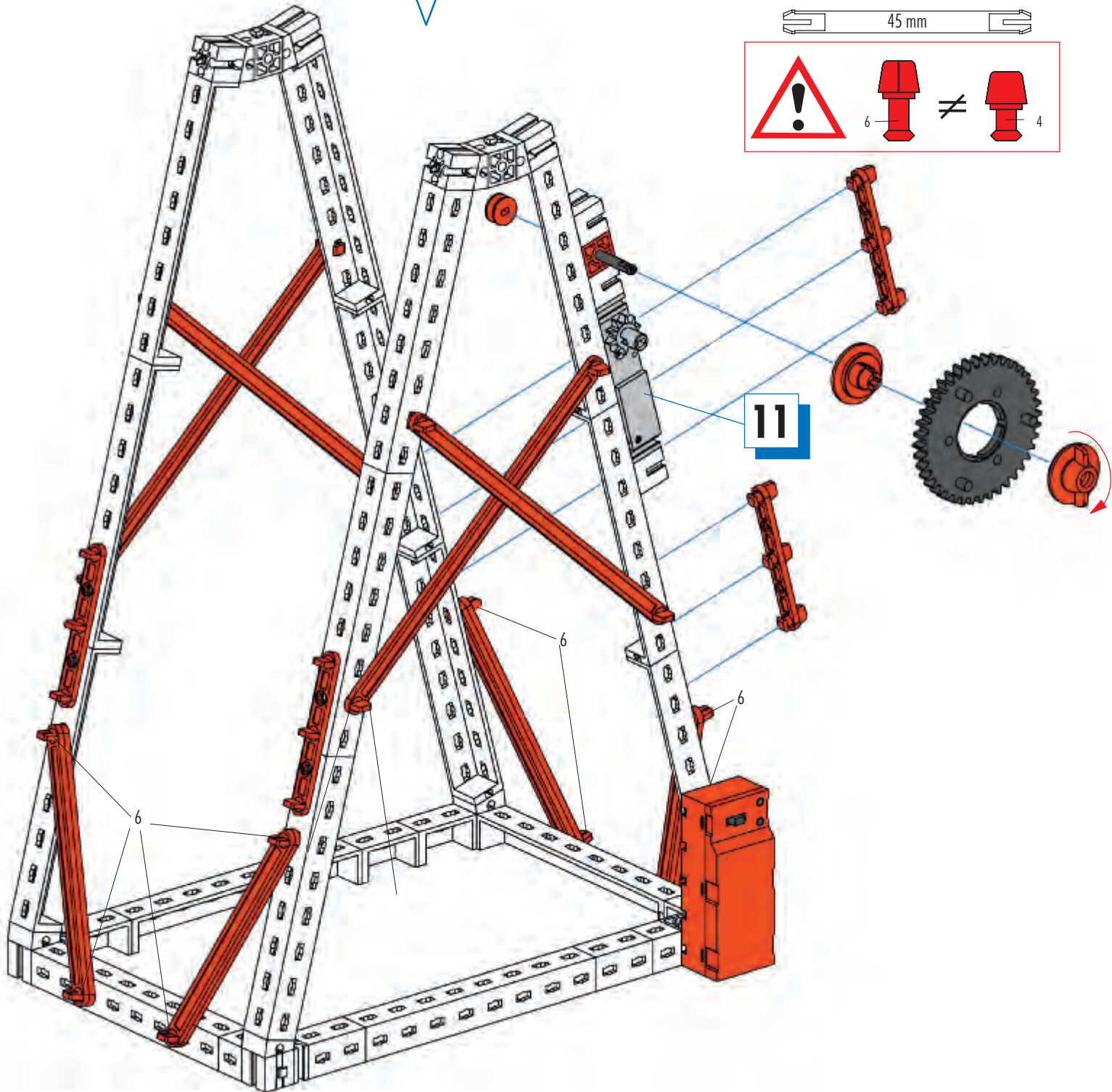
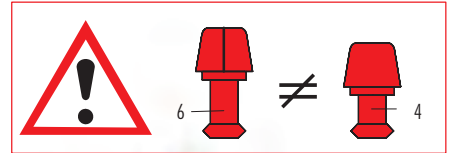
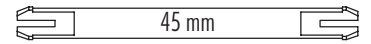
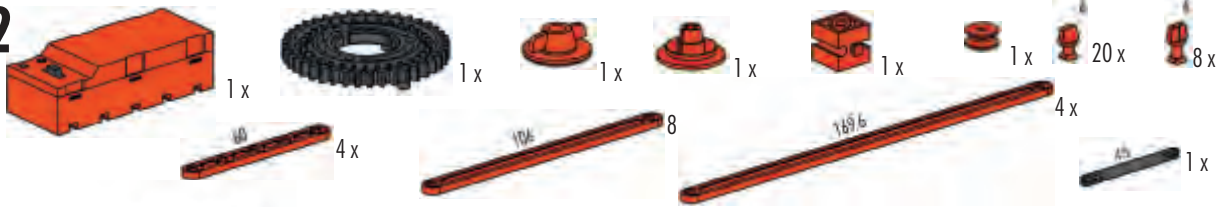

13

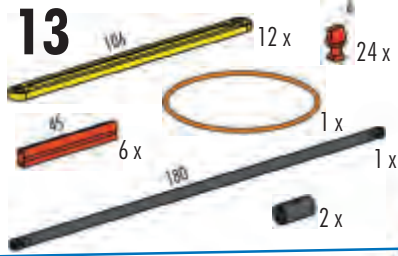

8

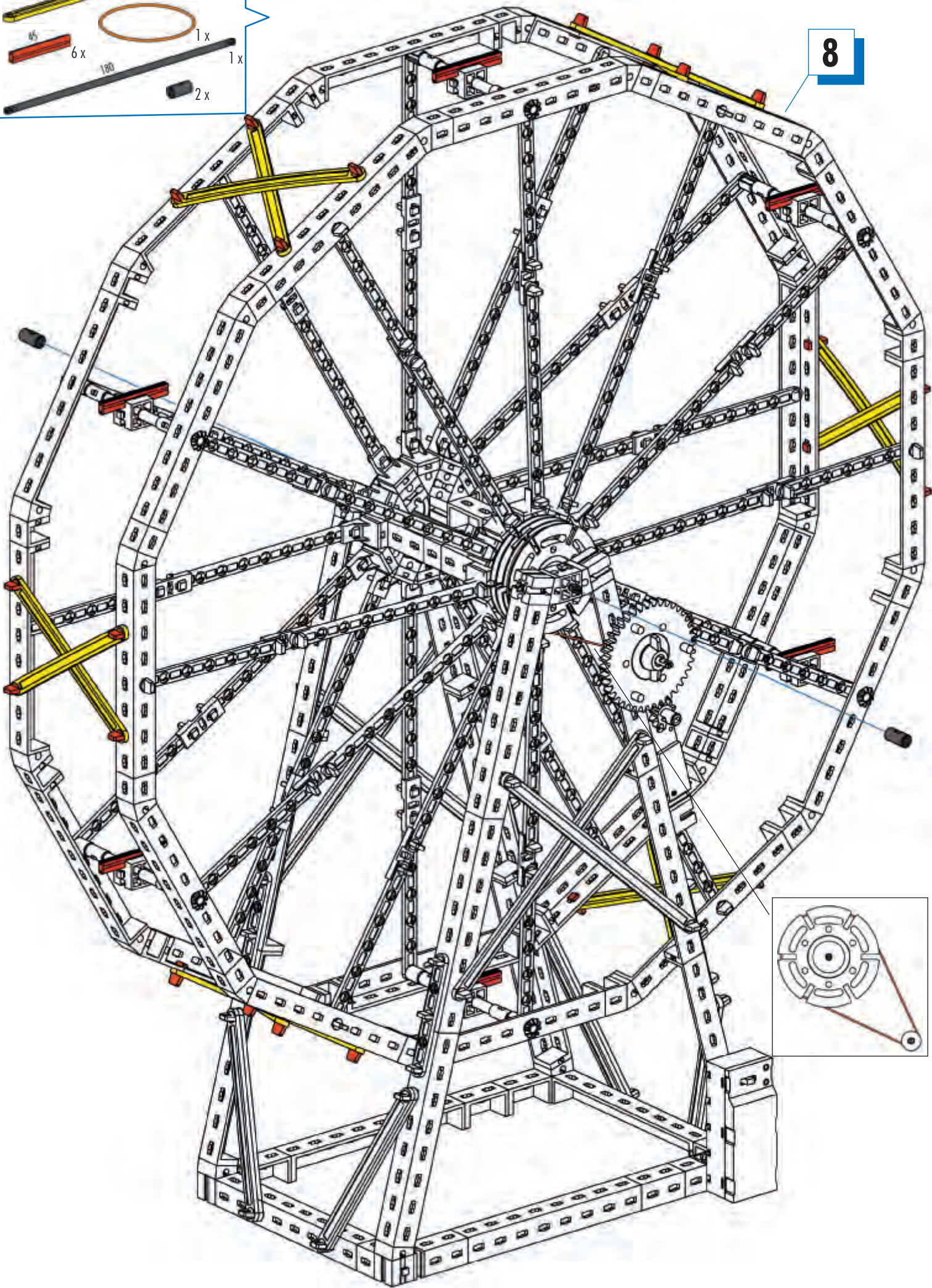

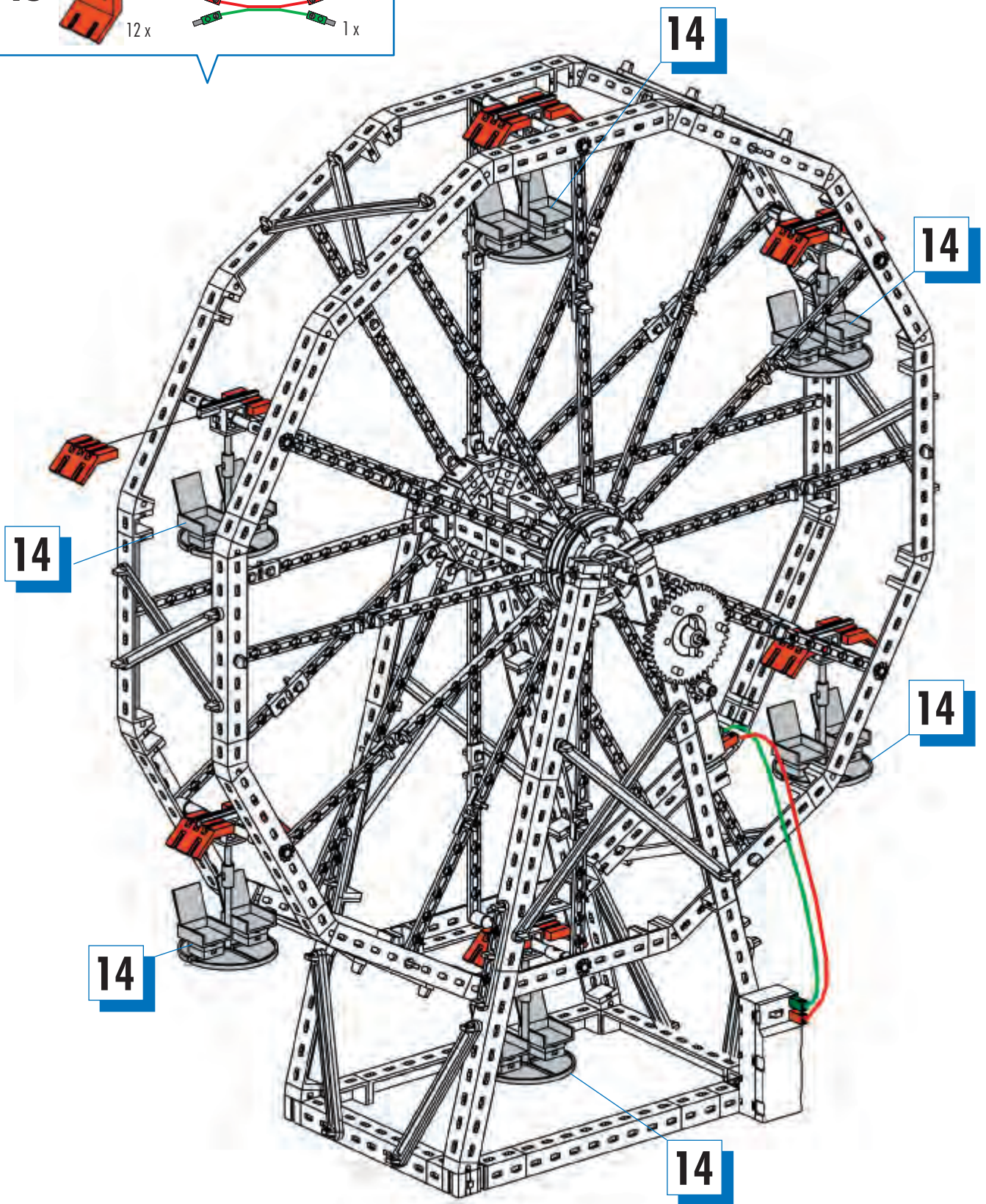
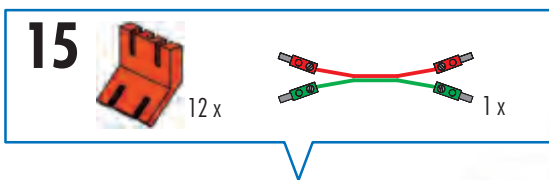
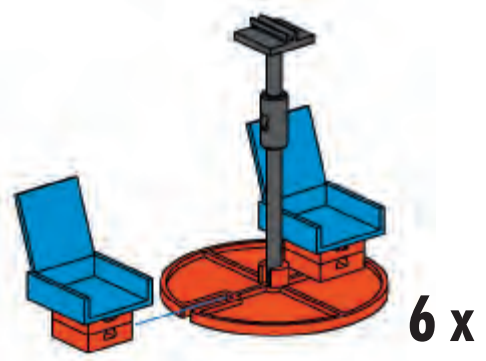
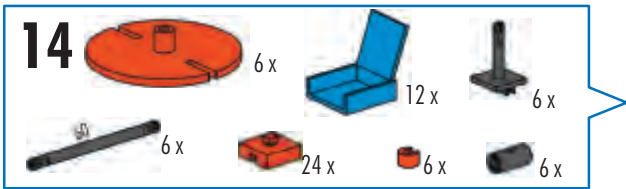



Sound + Lights

Sound + Lights
500 880

1

- 1x black 1x8 Technic beam
- 1x red 1x8 Technic beam
- 2x grey 1x2 Technic pins
- 1x orange 1x2 Technic pin
- 1x green 1x2 Technic pin
- 3x black 1x2 Technic pins





Karussell
Carousel
Carrousel

Mallemolen
Tío vivo
Carrocel

Giostra
Карусель
转盘

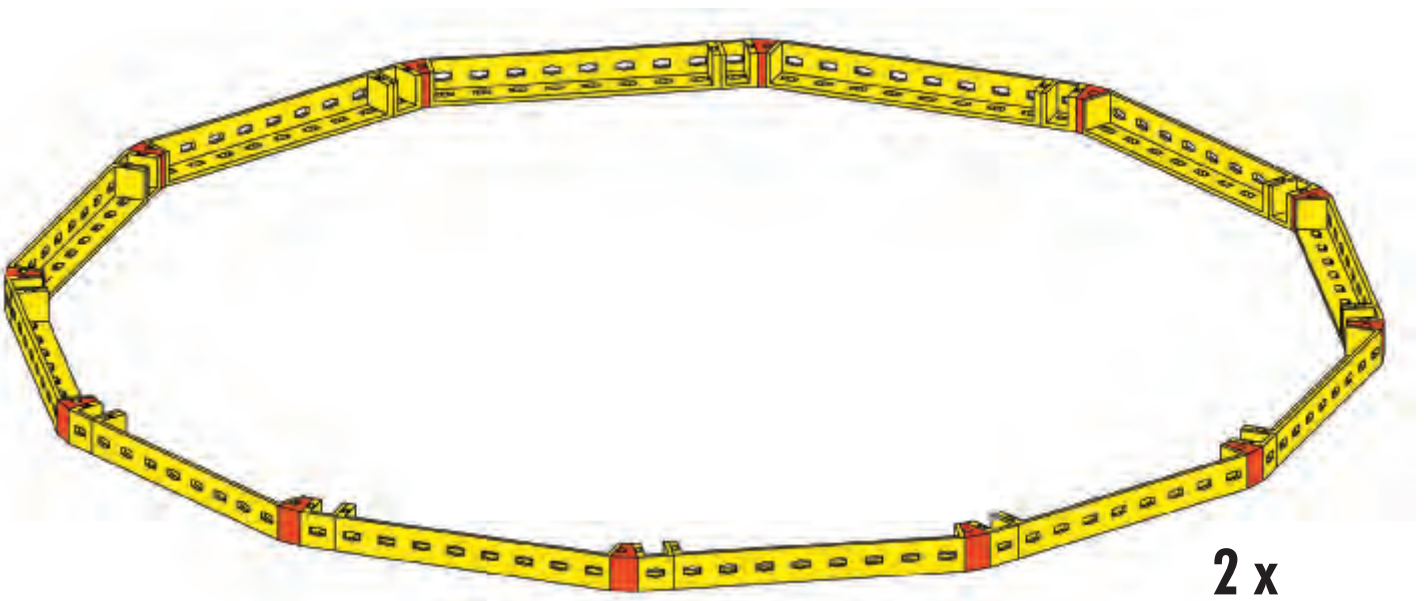
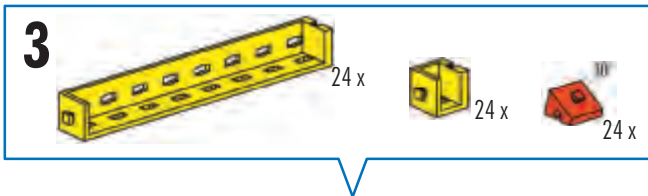
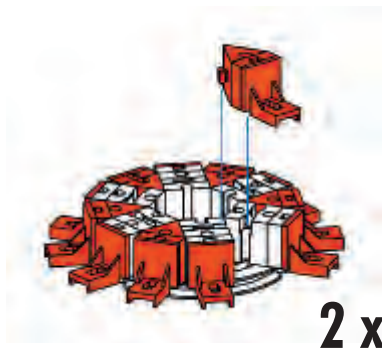
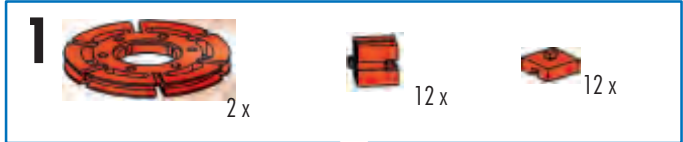

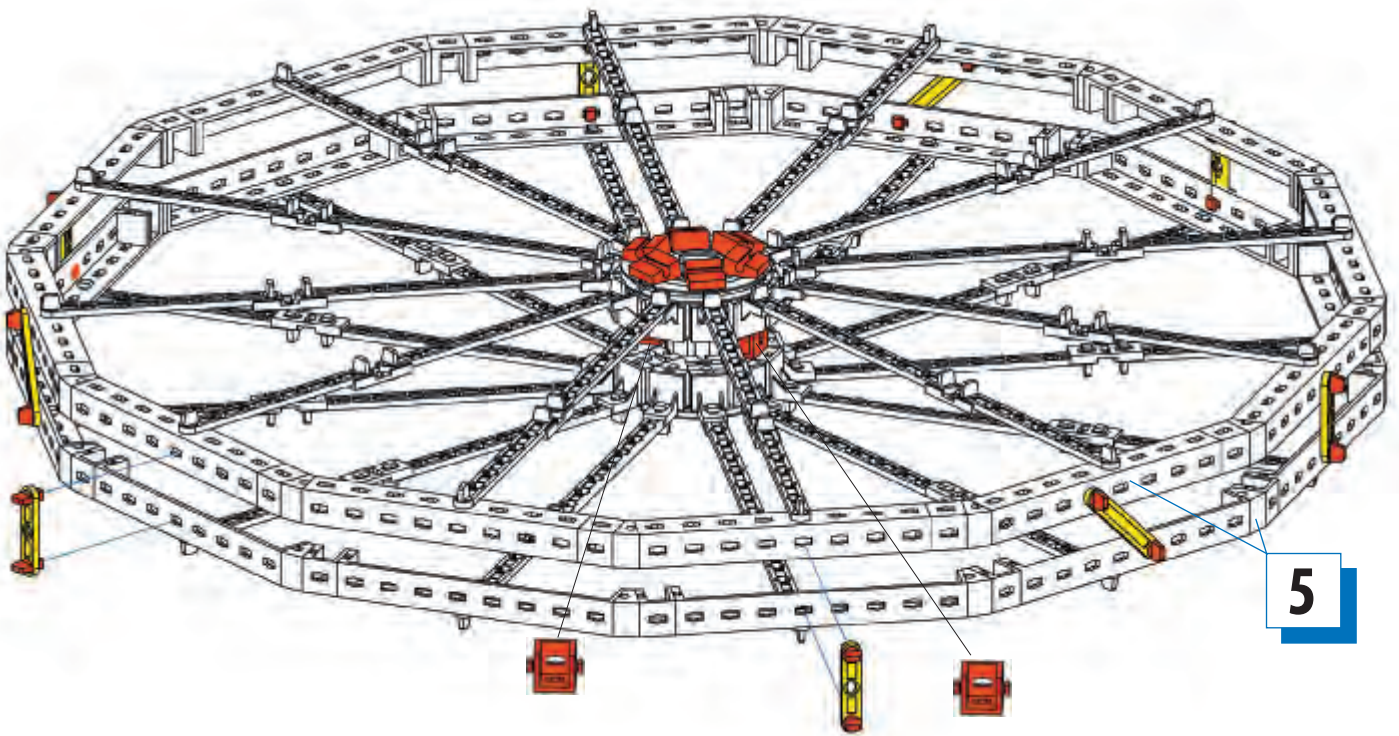
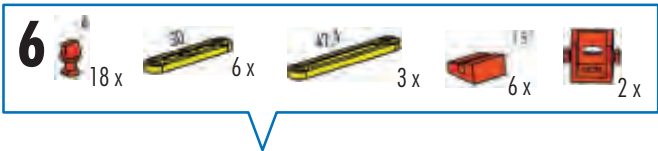
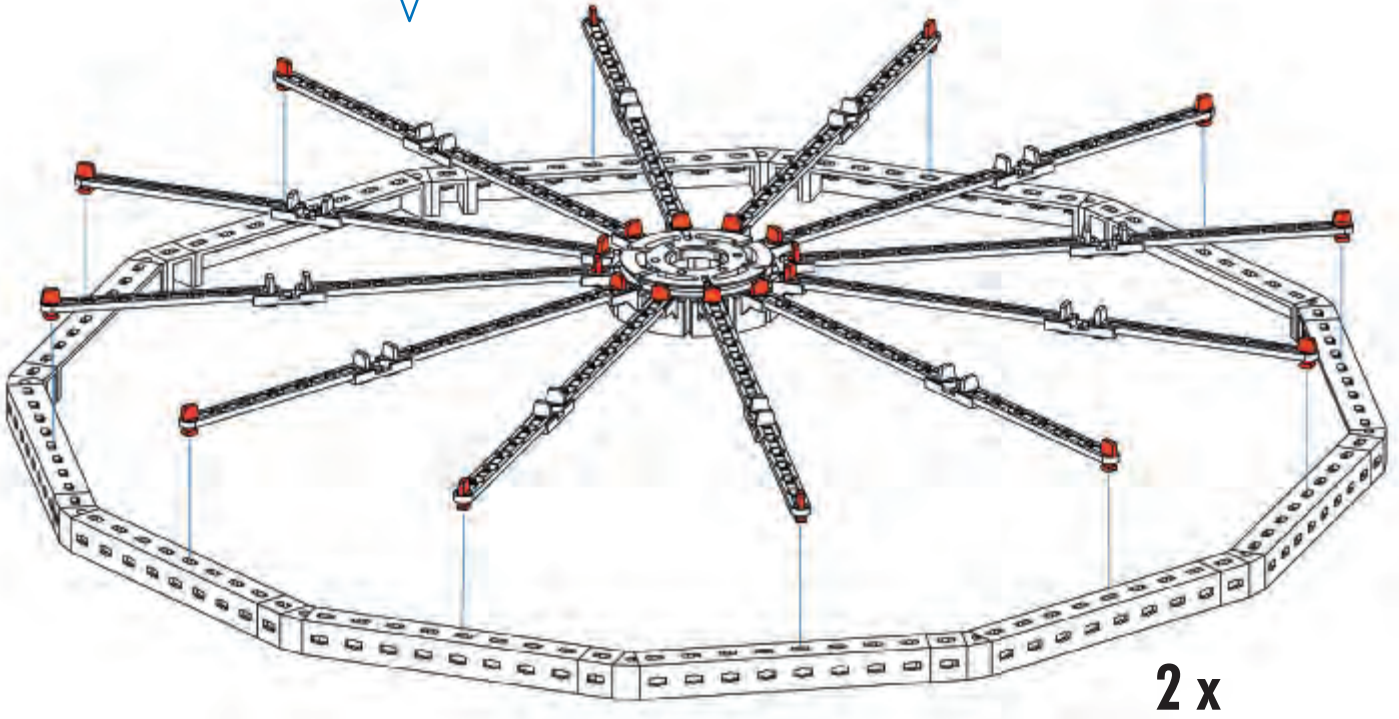
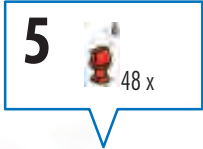
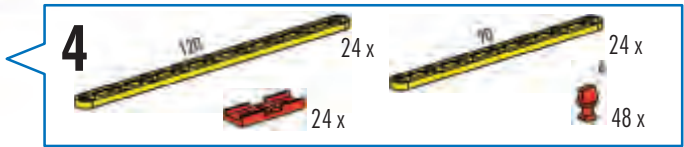
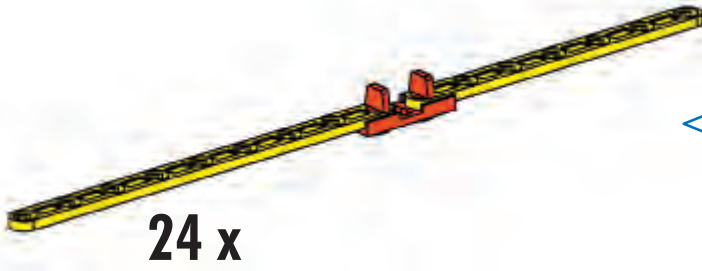

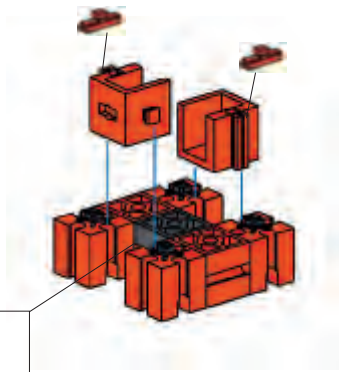

7 4x 2x 2x 1x 2x

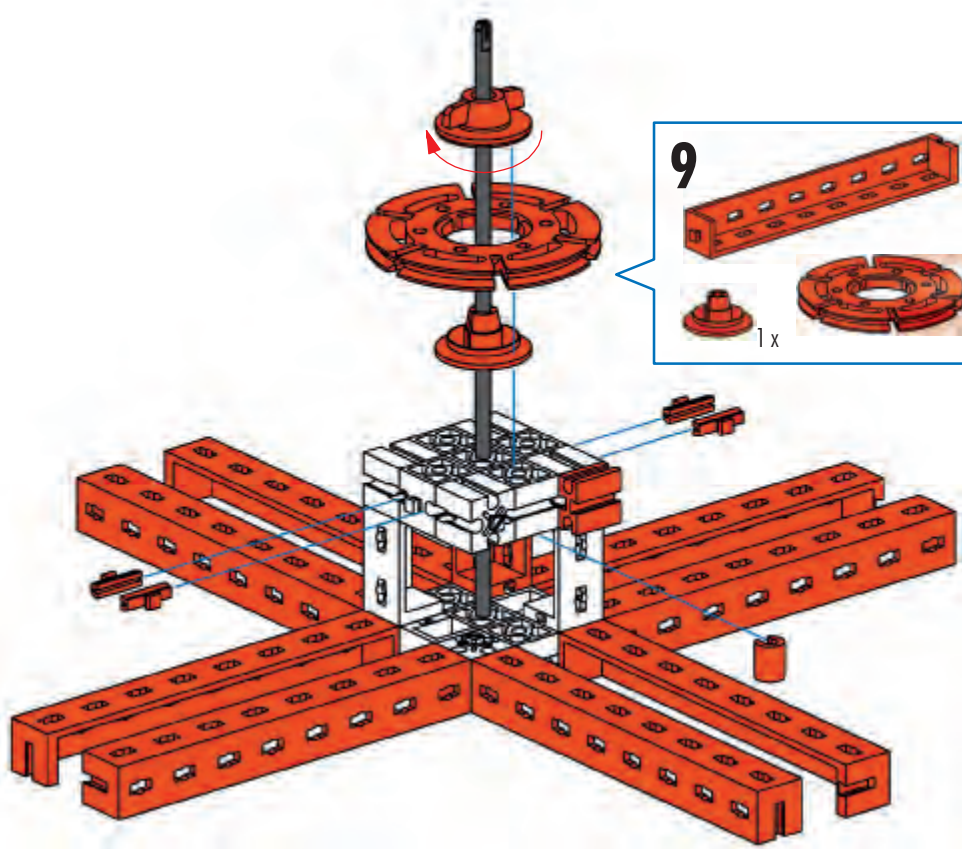
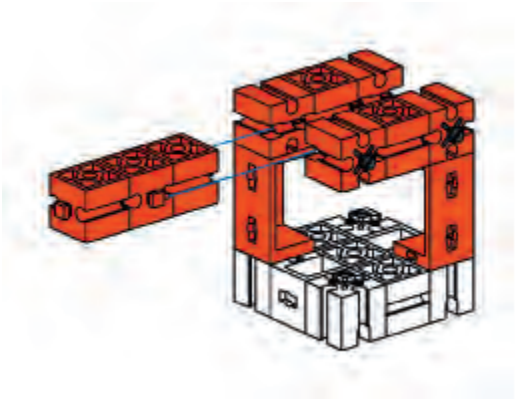

 Große Bohrung
 Large drilling
 Alésage large
 Grote boring
 Perforación grande
 Orificio grande
 Grande foro
 Большое отверстие
 大孔

8 4x 5x 2x

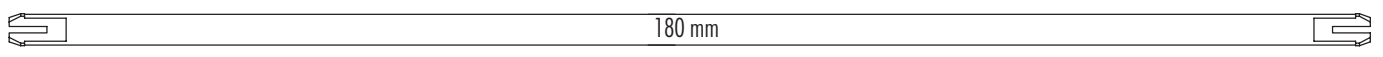

9 8x 1x 1x 1x 1x
 1x 1x 1x 4x

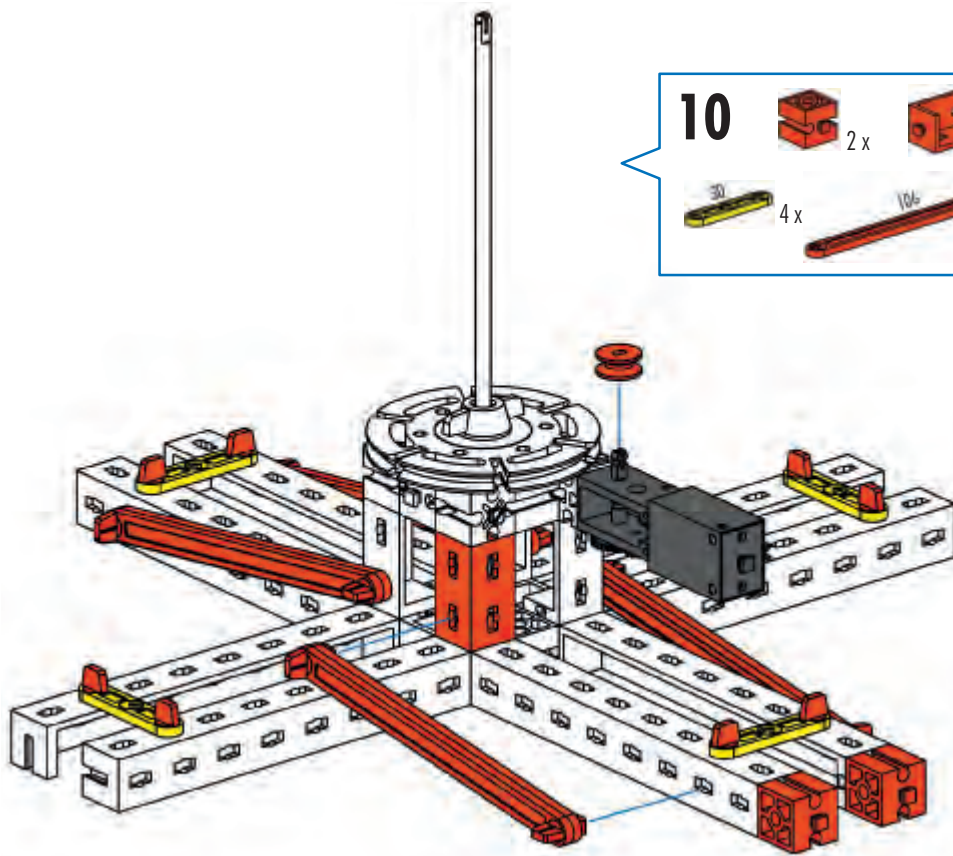



10

- 2x [Red 1x3 Technic Connector]
- 1x [Red 1x3 Technic Connector]
- 1x [Red 1x3 Technic Connector]
- 1x [Red 1x3 Technic Connector]
- 8x [Red 1x3 Technic Connector]
- 8x [Red 1x3 Technic Connector]
- 1x [Grey Motor]
- 1x [Grey Motor]
- 4x [Yellow Technic Pin]
- 8x [Red Technic Axle]

Warning: \neq

11

- 1x [Red 1x3 Technic Connector]
- 4x [Red Technic Axle]
- 1x [Red Technic Ring]
- 8x [Red 1x3 Technic Connector]

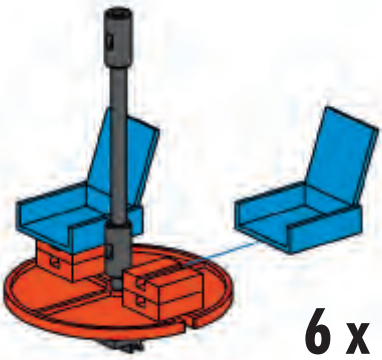
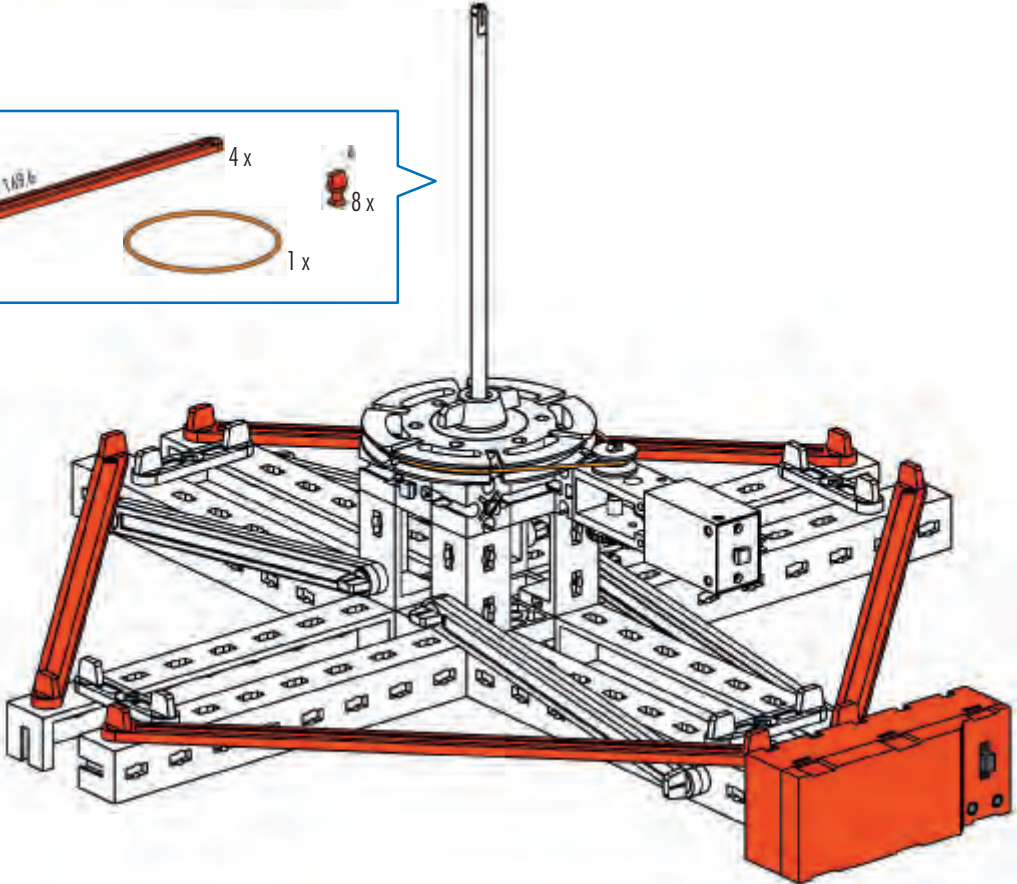

12

- 6x [Red Technic Ring]
- 12x [Blue Technic Chair]
- 6x [Grey Technic Pin]
- 6x [Red Technic Axle]
- 24x [Red 1x3 Technic Connector]
- 12x [Red Technic Pin]

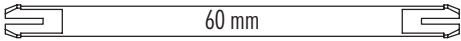

13



6x



3x



3x



12x



6x



6x



6x

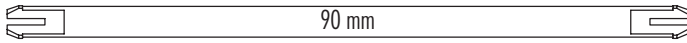

90 mm

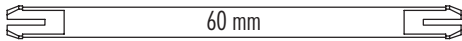

60 mm

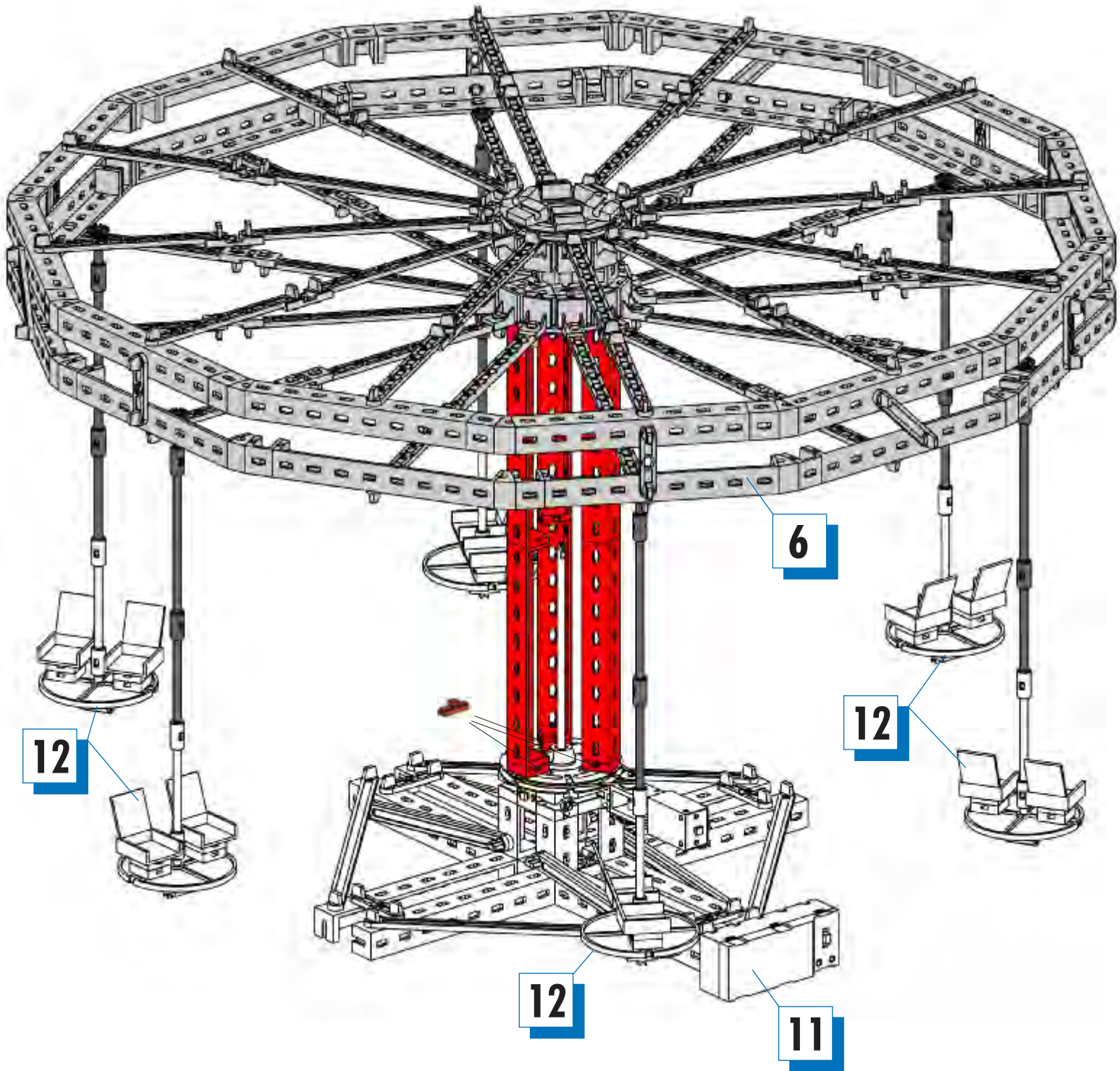

6

12

12

12

11

14



Sound + Lights

Sound + Lights
500 880

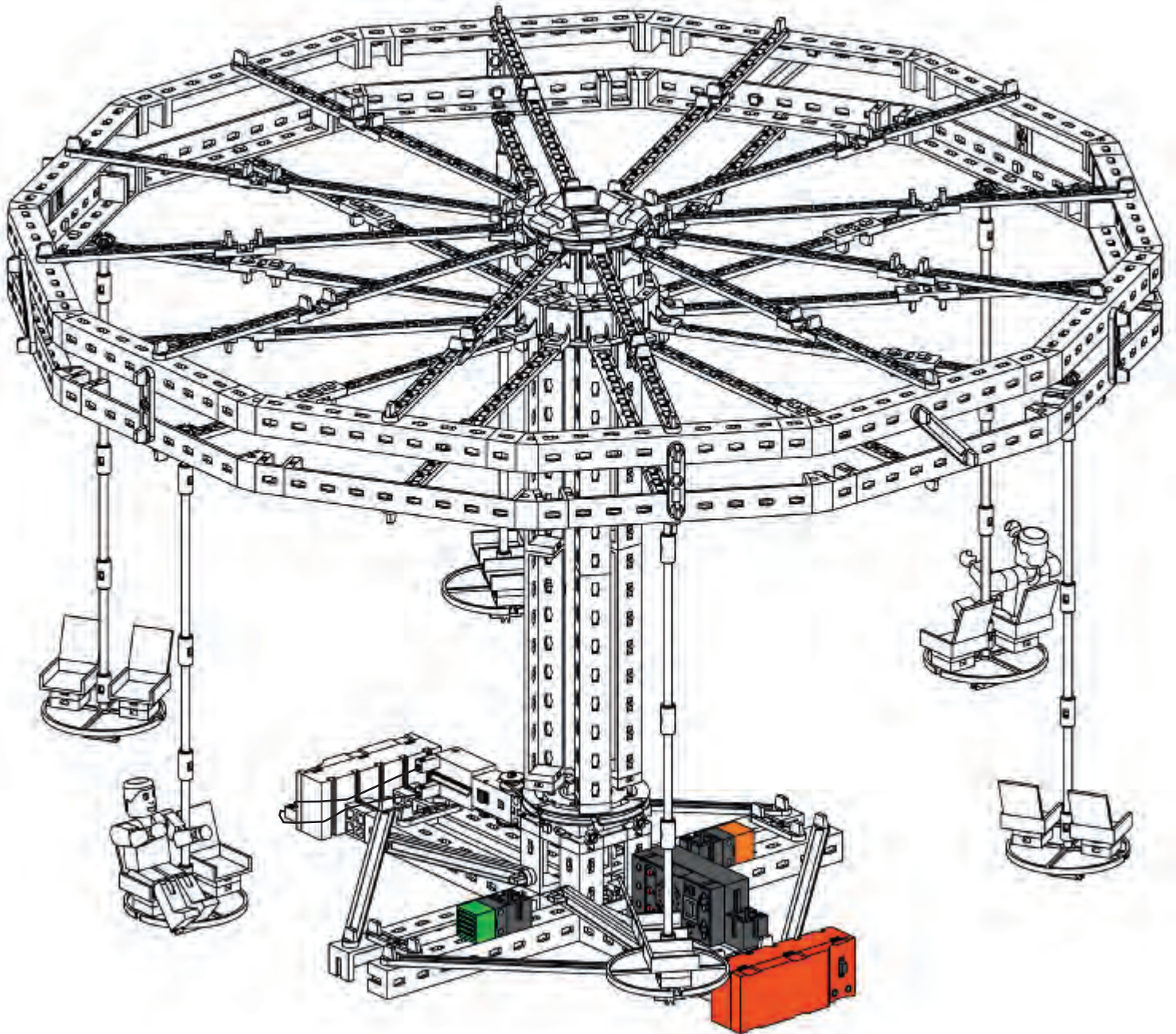
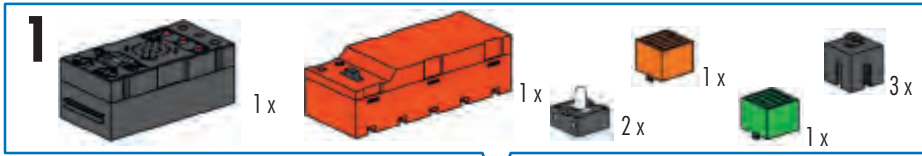



Zentrifuge
Centrifuge Ride
Centrifuge

Centrifuge
Centrifuga
Centrífuga

Centrifuga
Центрифуга
离心机

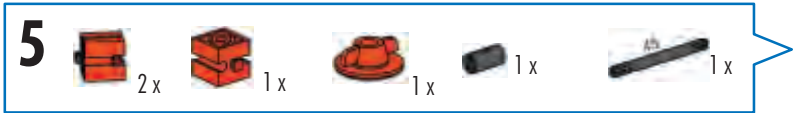
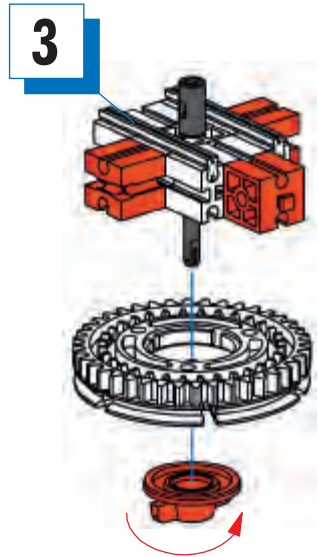
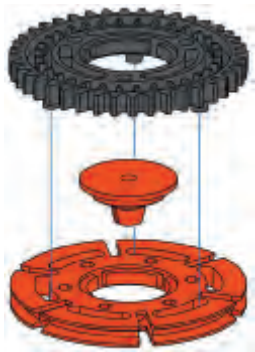
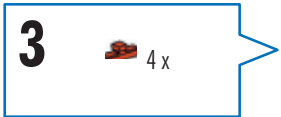
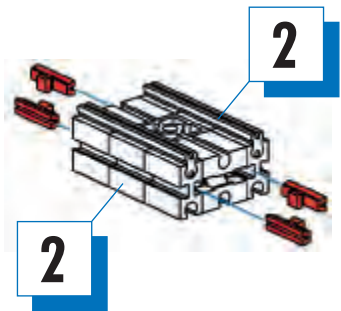
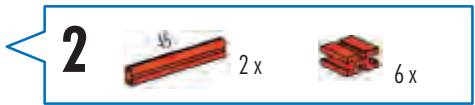
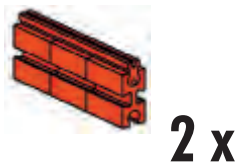
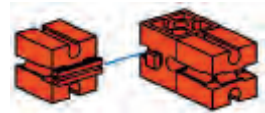

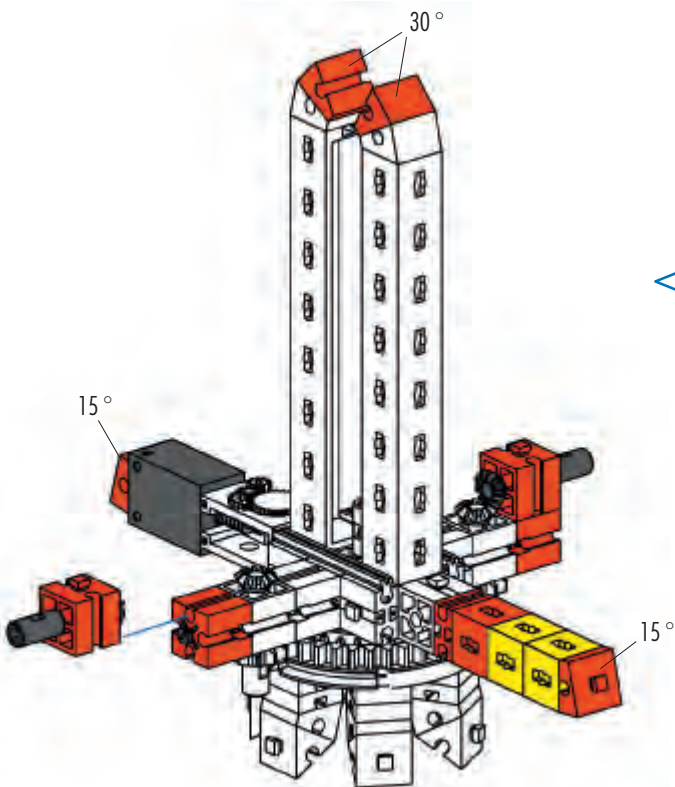
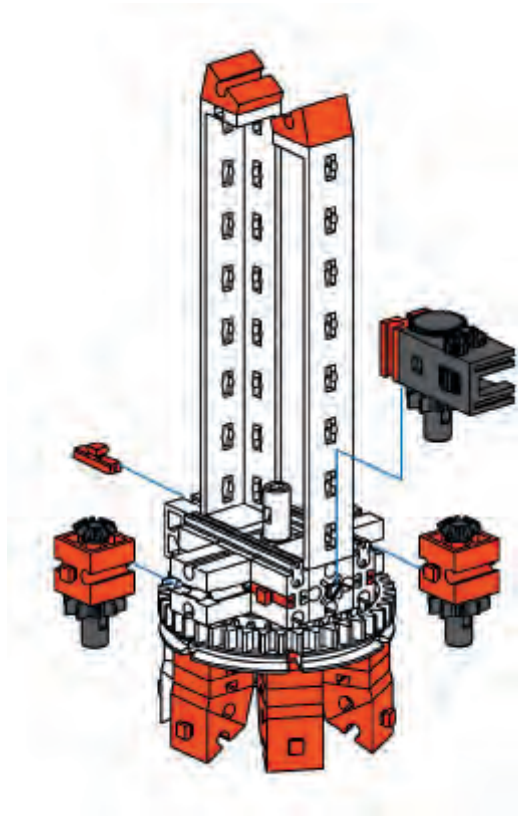
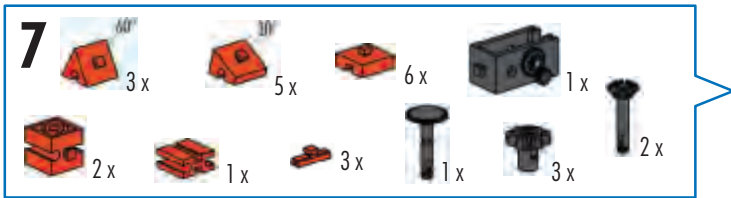
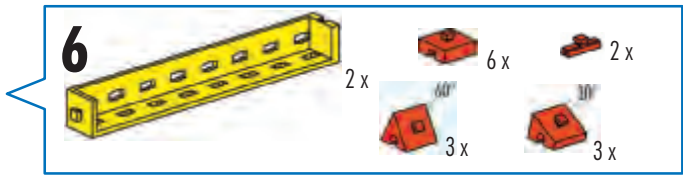
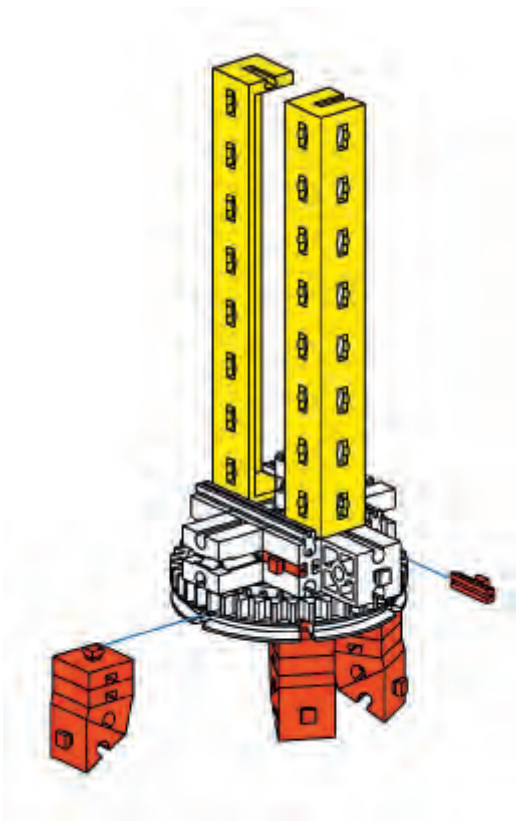

9

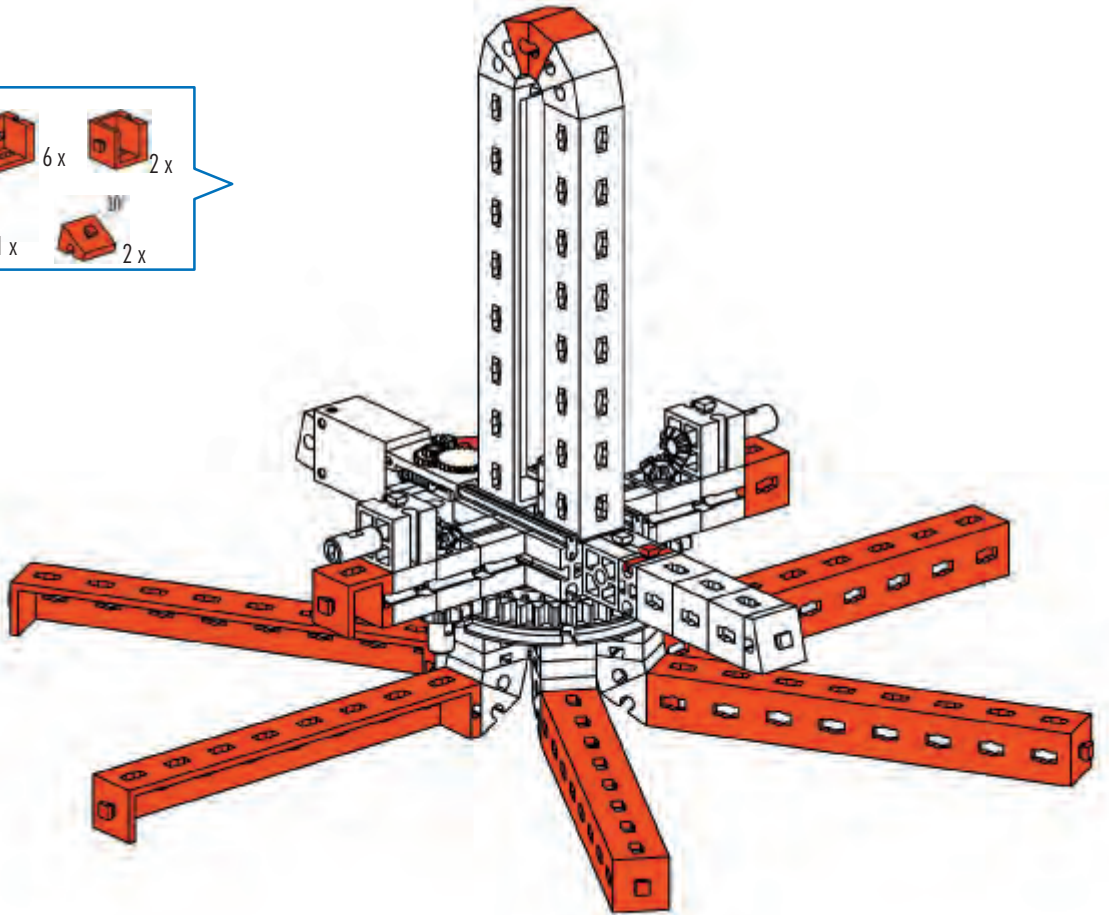
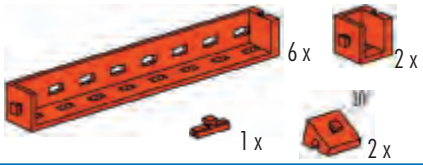

10

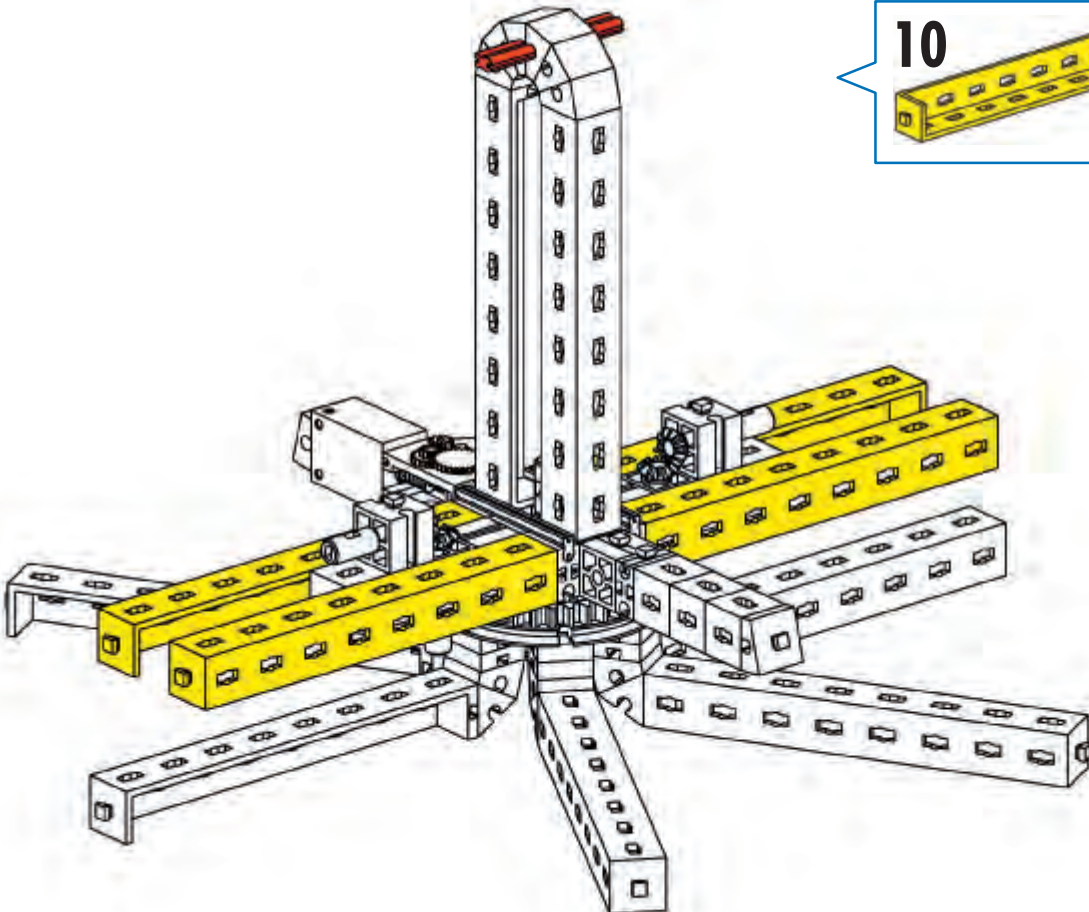

11

6x 6x 6x 4x 4x 2x

60 mm

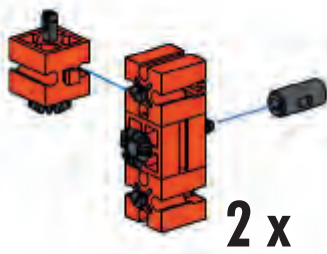
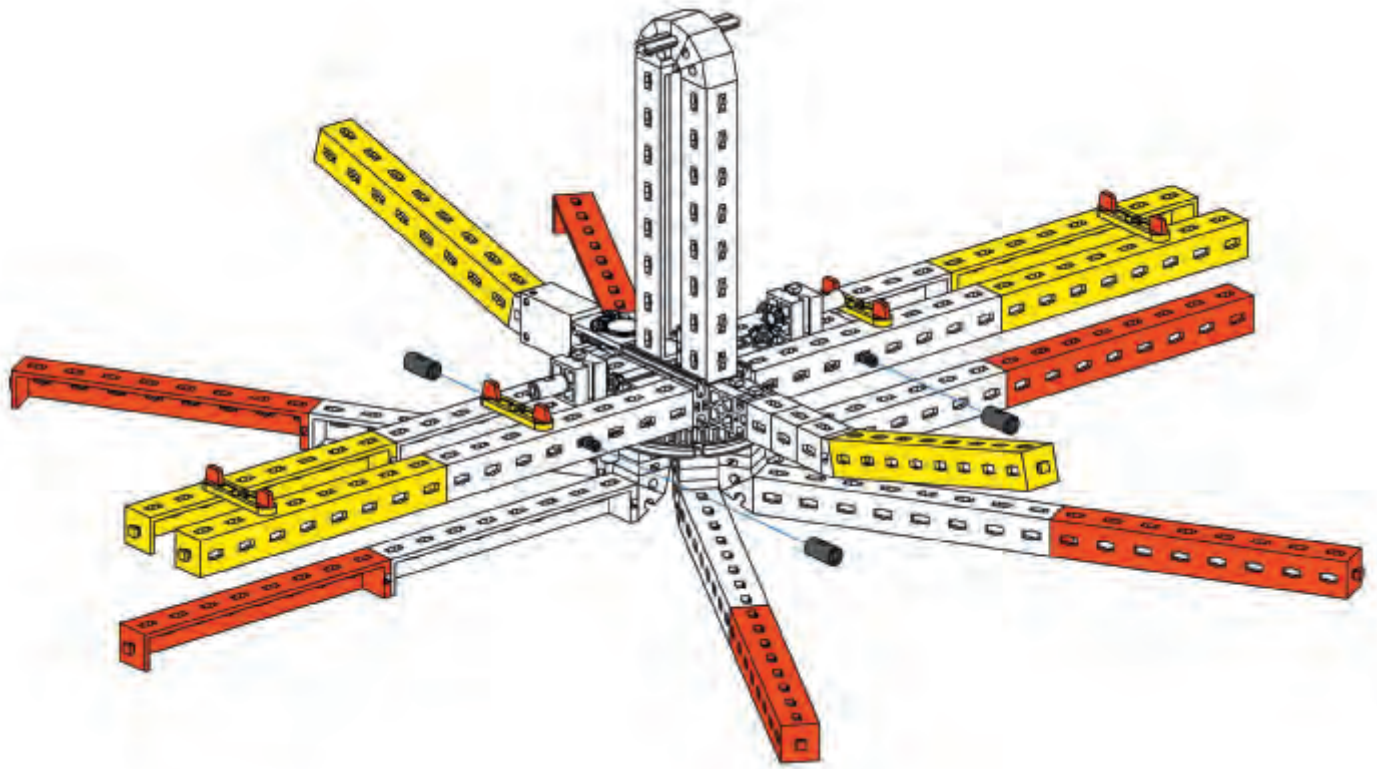

12

4x 4x 2x 4x

13

2x 2x 2x 4x

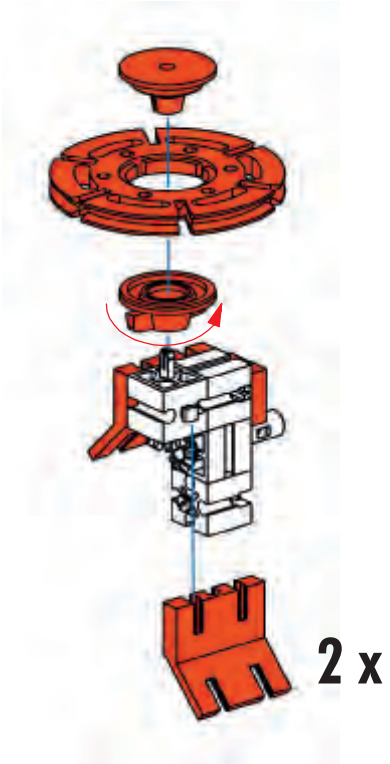

- 14**
- 18x
 - 1x
 - 4x
 - 4x
 - 8x
 - 4x
 - 4x
 - 3x
 - 3x
 - 6x
 - 106
 - 106
 - 106
 - 180
 - 1x
 - 2x
 - 40
 - 1x
 - 60
 - 90
 - 180
 - 1x
 - 3x
 - 4x
 - 6x
 - 3x
 - 3x
 - 1x

13

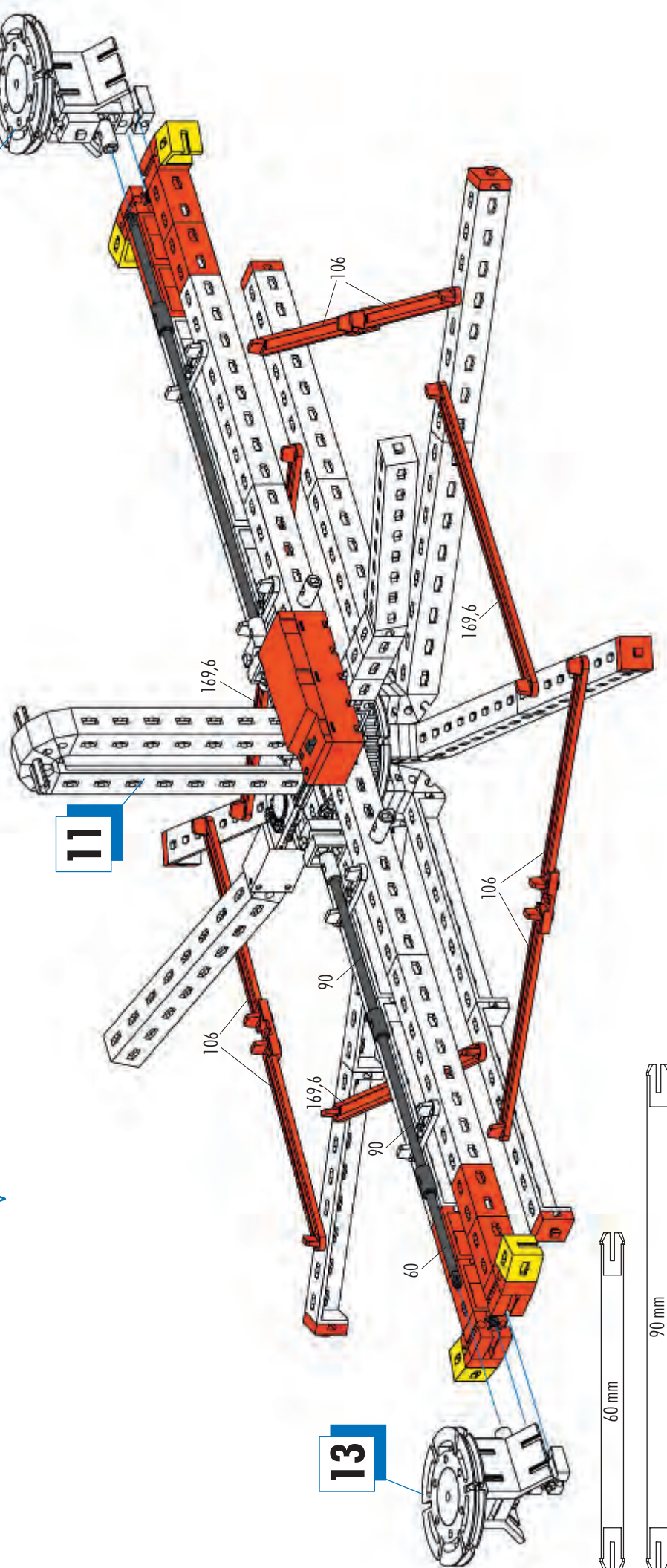

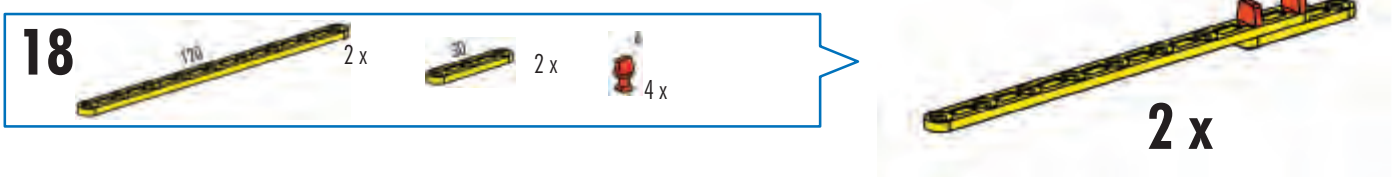
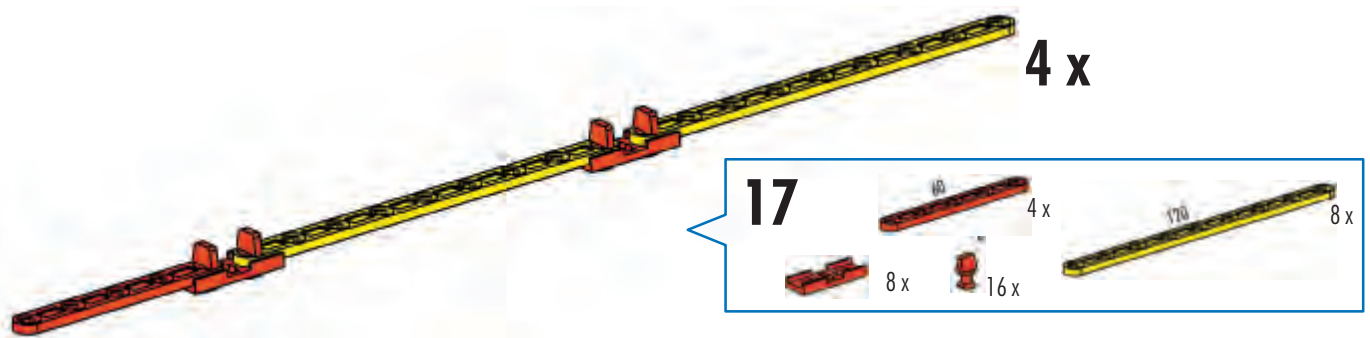
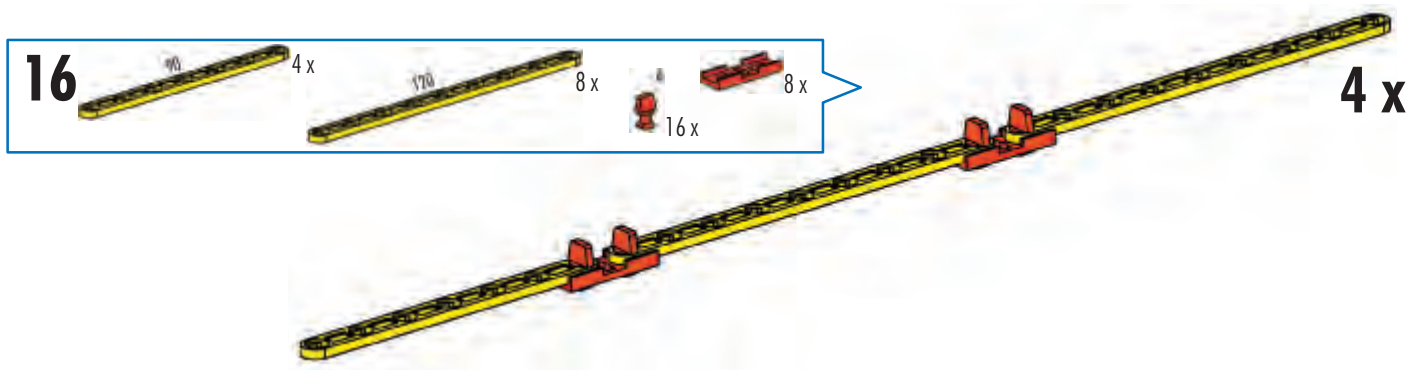
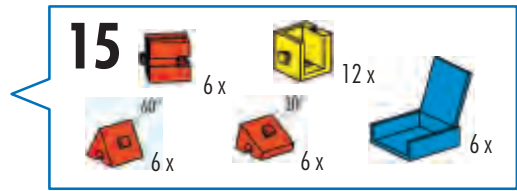
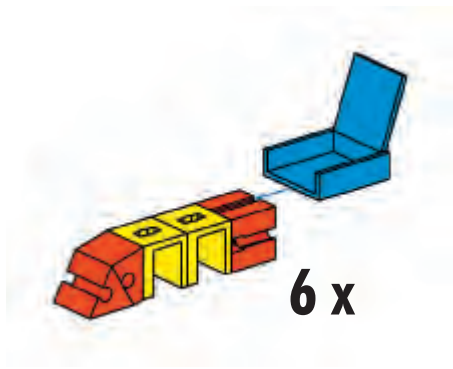

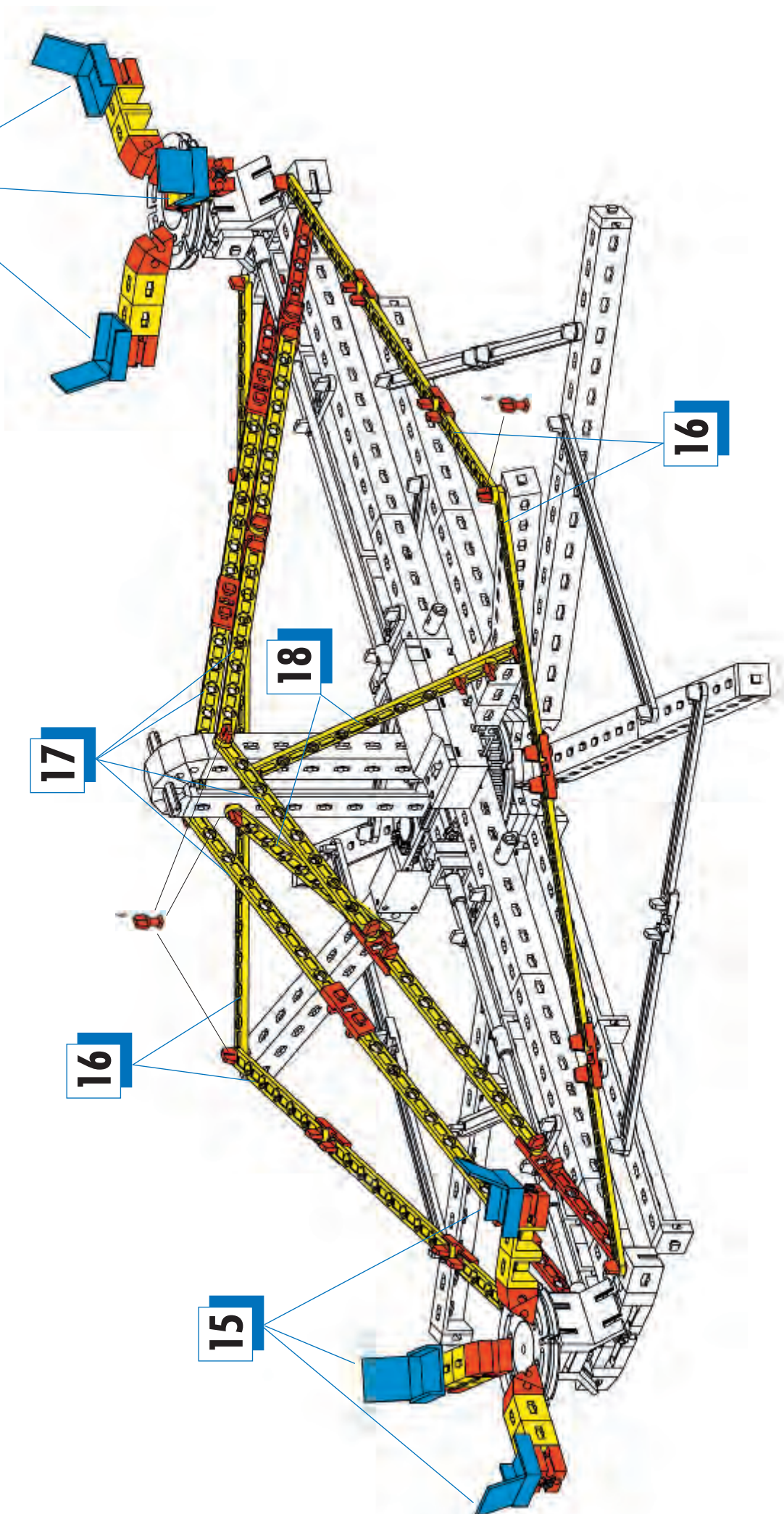
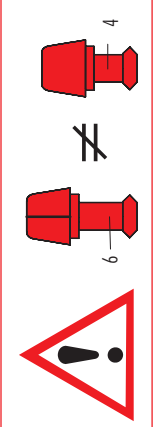
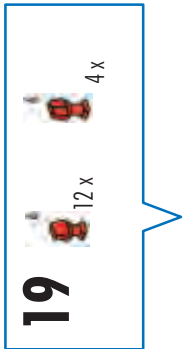

20

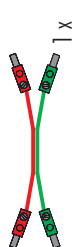

1 x

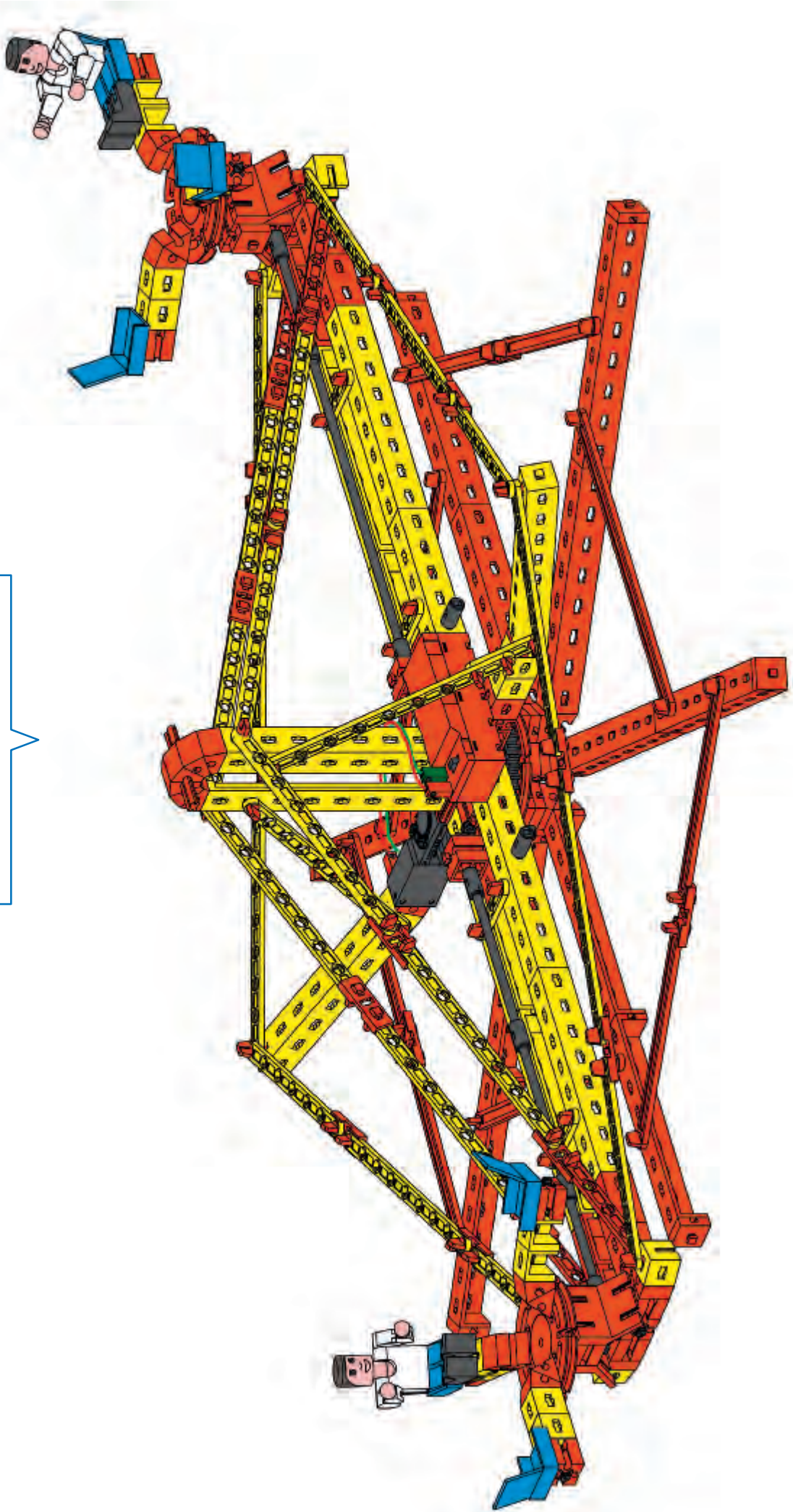

Sound + Lights

Sound + Lights
500 880



Schaltplan
Circuit diagram
Plan électrique

Schaltplan
Diagrama de circuitos
Plano eléctrico de ligação

Schema elettrico
Схема подключения
电路图

