

Wind Drive	P. 13
Balloon Drive	P. 14
Bending Rod Drive	P. 15
Rubber Band Motor	P. 16
Pullback Motor	P. 17
Trike	P. 17
Buggy	P. 17
Vehicle with Steering	P. 18
Offroad Vehicle with Steering and Spring Suspension	P. 18
Offroad Vehicle with Pullback Motor	P. 19
Remote Controlled Offroad Vehicle	P. 20

Contents





"Hi, first I'd like to introduce myself. I am your **fischertechnik trainer** and will accompany you through the entire activity booklet. As you can see from the pictures, together we are going to build various models each equipped with a different drive. I hope you have a lot of fun building your models!"



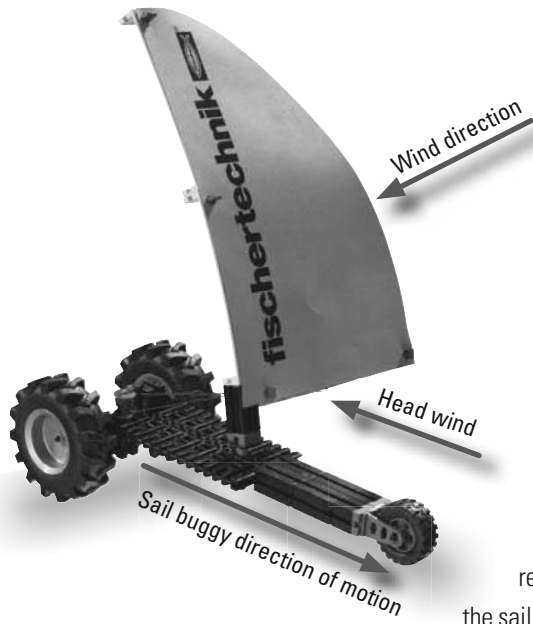

■ "You may find this hard to believe, but in the Internet I found out that the oldest remains of a sail buggy were found in the grave of an Egyptian Pharaoh. Amenemhet, as this Pharaoh was named, may have ridden through the desert on wheels propelled by a sail nearly 4,000 years ago." The figure shows a painting, illustrating a wind-propelled vehicle with sail.

The surface on which sail buggies or sail trikes run, such as sand, produces a resistance to the forward motion of the vehicle. The driving or propulsion force for overcoming this resistance are the forces produced by the wind hitting against the sail. The next fischertechnik model demonstrates how wind can be used in this manner for propulsion. Build the sail buggies as described in the assembly instructions.

■ In your model the fischertechnik sail attached gives the wind the required resistance to move the vehicle. The graphic depiction shows that the wind can be utilized best when the sail is at an angle. The wind then hits the surface of the sail, thus pushing the sail buggy forward. If the wind comes from the other side, it is necessary to change the position of the sail. The motion of the sail buggy generates a head wind, or relative wind.

Wind Drive



...over 4,000 years ago



Task 1

Use a stopwatch to measure the time and distance with different sail positions.



Task 2

Measure the time and distance of your model at various wind velocities. For this purpose use a hair drier or fan, which you can set to different speeds.



Balloon Drive

■ Is it possible to propel a vehicle without motor or batteries, using only a balloon? You can find out in this chapter.

Task 1

Blow up a balloon and let it go. You can see that the balloon flies along an uncontrolled path.

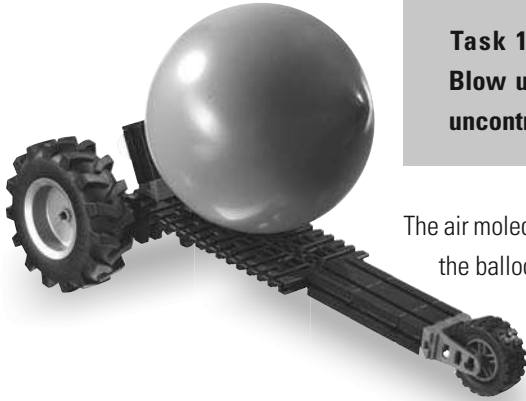

The air molecules escape from the balloon, propelling it forward. This produces a reaction, or recoil. Since the balloon is not guided, it buzzes through the air uncontrolled until it is nearly empty and then falls to the floor.

■ Build the model as described in the assembly instructions.

Task 2

Now blow up the balloon in the model. Place the vehicle on a smooth surface and then open the end of the balloon. Observe how the model behaves.



When you open the end, the air escapes from the balloon. The force of the escaping air acts in the opposite direction. Your vehicle is propelled as a reaction to the escaping air.

Rockets are shot into outer space using this same reactive force.



Task 3

Blow up the balloon with different amounts of air and observe how far your vehicle travels each time. Does the vehicle move faster when the air in the balloon is nearly exhausted?



Yes

No



■ "Use of a bending rod to drive machines, goes back to ancient times. Even then projectiles such as stones or arrows were accelerated to tremendous speeds using mechanical energy. The figure shows a catapult used in the middle ages. A large stone was placed in a basket and the ropes were tensioned with a winch, causing the rod to bend downward. After removing a bolt, the rod snapped back to its original position rapidly, hurling the stone great distances to its target.



Bending Rod Drive

■ Build the vehicle with bending rod as described in the assembly instructions.

Task 1

Let the vehicle move a certain distance.

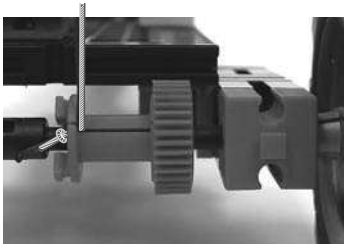

For this purpose thread the blue string through the opening provided for this purpose in the axle. Pulling the vehicle back, winds the string around the axle, tensioning the flexible spring.

When the vehicle is released, the bending rod returns to its vertical position. The string is unwound from the axle, causing the vehicle to move.



Task 2

Use a stopwatch to measure the time and distance on different running surfaces such as carpeting and tile. Which surface allows the vehicle to move farthest and fastest?

Ensure that the bending rod is tensioned equally each time.



Running surface	Time	Distance
Carpeting		
Tile		



Rubber Band Motor

■ In a rubber band motor, a rubber band is fastened between two points, tensioning it. Energy is stored by winding up and is released as soon as the rubber band can return to its original position. "I found out that a French engineer named Alphonse Pénaud invented the rubber band motor in 1870. He powered small model airplanes with this propulsion technique. They flew powered by the force of the tensioned rubber band. The "tensioning force of the rubber band" was decisive for the distance flown.



Task 1

Stretch the rubber band and then let it go. Stretching it requires you to exert a certain force. This force is released when the rubber band snaps back.



■ This is the same principle used in your model with rubber band motor. Using the assembly instructions, build the model. The rubber band is tensioned when the rear axle is turned backward. When the vehicle is released, the rubber band returns to its original length, thus propelling the vehicle.

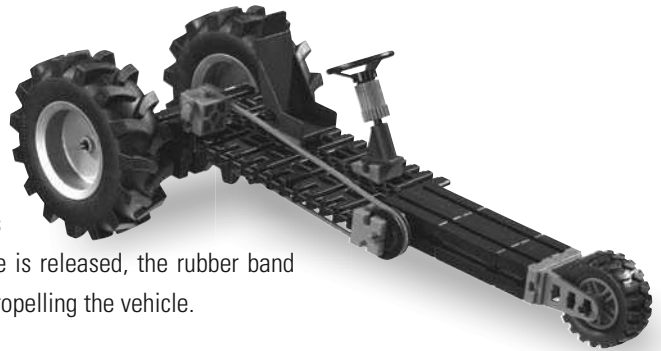

Task 2

Use your model to test how the rubber band motor works. Observe the speed. When does it reach the highest speed?



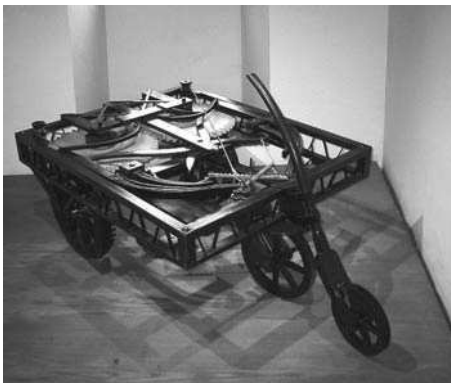

■ "What does Leonardo da Vinci have to do with a pullback motor? In his sketches he left a model of a three-wheeled vehicle. This motor consisted of components such as wooden springs and gears. The springs were tensioned by muscular force. The energy stored in the springs was then transferred to the drive wheels when a catch was released.

Pullback Motor

■ Build your three-wheeled model with the aid of the assembly instructions. When assembling, ensure that the motor is installed in the correct position. The arrow on the motor housing indicates the direction in which your vehicle will move later. The pullback motor contained in the construction set can be wound up by pulling the vehicle backwards. When the vehicle is released it starts moving.

Trike

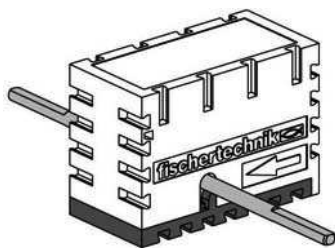

What happens in the motor? The motor consists of gear, a wound-up spring, shafts and a housing. The spring is permanently connected to the housing and to a shaft over the gear. The spring is tensioned in the same manner as winding up a clock. When the vehicle is released the spring unwinds, transferring the stored energy to the gears and then on to the wheels. This sets the vehicle in motion.

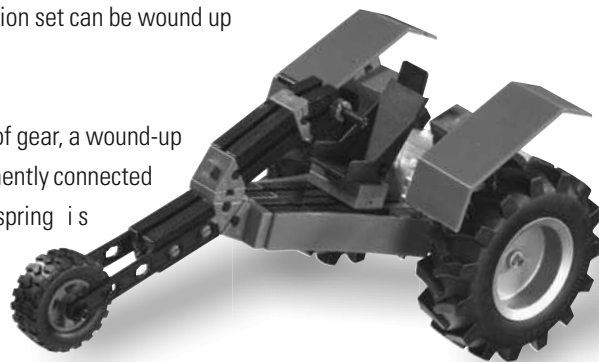

Task 1

How far does your three-wheeled model travel? Compare the distance to the four-wheeled buggy, which you build next. Is it true that the four-wheeled model does not travel as far as the three-wheeled model when the pullback motor is wound up equally due to the additional friction?



True Not true

Task 2

Compare the two models. Which advantages or disadvantages does the trike have in comparison to the buggy? What can you observe, for example, regarding the directional stability of the two models?



■ As already mentioned, you can now build a model with four wheels, which is propelled with the aid of a pullback motor. Use the assembly instructions to build the buggy and complete the last two assignments.

Buggy

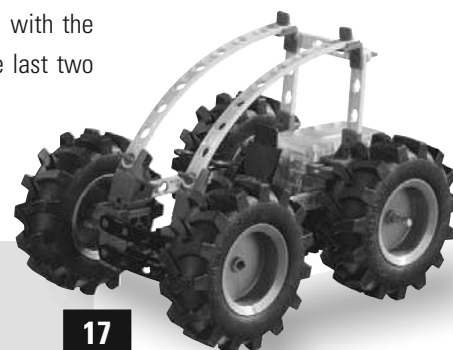

Vehicle with Steering

■ With this model you can determine the direction in which your vehicle travels yourself with the aid of the axle pivot steering - also known as kingpin or Ackermann steering. Build the model as described in the assembly instructions and see how steering works.

Axle pivot steering was invented in 1816 by a carriage builder from Munich by the name of Georg Lankensperger. Its function is actually quite simple. A so-called double trapezoid layout is used to allow the car to drive through curves. This consists of an axle element, a tie rod and two steering arms or 'pitman' arms.

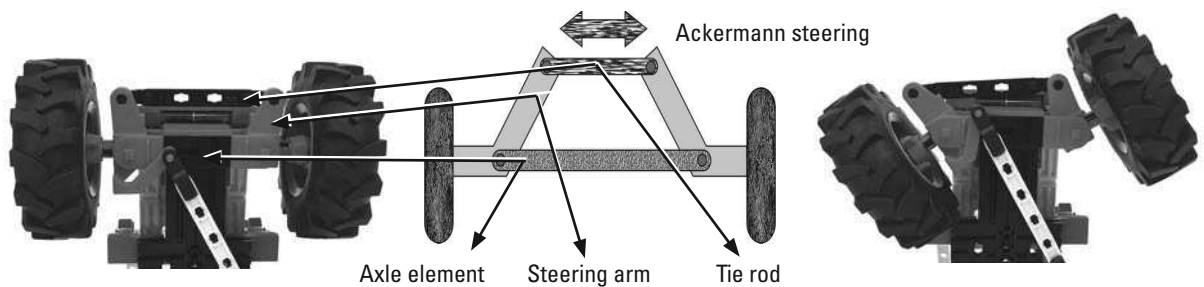

The steering wheel is connected to the tie rod by a rack and pinion. When you turn the steering wheel in one direction, the steering arms turn the wheels as well as the axle in this direction. Due to the trapezoidal layout the outer wheel moves through a larger arc than the inner wheel, making the cornering more precise.

Offroad Vehicle with Steering and Spring Suspension

■ Your next model also has a steering function as well as being equipped with a spring suspension system. Build the offroad vehicle with the aid of the assembly instructions.

Task 1

Why do you think vehicles have a suspension system?



The basic purpose of a suspension system in a vehicle is to take up the bumps in the road. The suspension allows the wheels to follow irregularities in the road giving them the greatest possible road contact and thus the maximum gripping ability. This increases passenger comfort as well as driving safety and vehicle protection.

Task 2

Push your model over an uneven surface, with small pebbles or other small obstacles and observe how the suspension works. What differences can you see in comparison to your previous model without suspension?





■ In the next step you can install a pullback motor in your offroad vehicle with steering and suspension functions.

Offroad Vehicle with Pullback Motor

Task 1

Install the pullback motor in your existing model as described in the assembly instructions. Then test the directional stability of your model. What can you observe when operating your model? Does the vehicle remain on a defined track?



For this purpose I recommend marking a straight, long track on the floor with a width of approx. 50 cm.

The vehicle runs off track, because the steering system is not stable.

Task 2

Do you have any idea how you could improve the directional stability of your model?

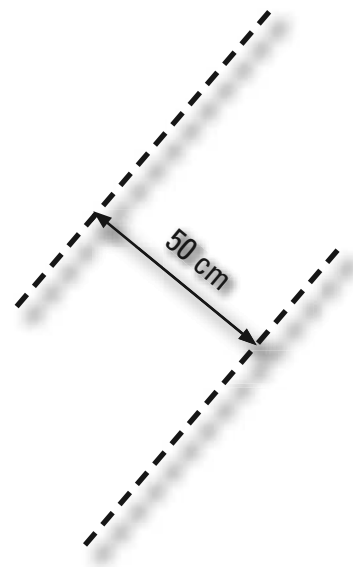

To keep the vehicle on track it is helpful to arrest the steering on your offroad vehicle. The illustration below shows you how you can arrest the steering on your vehicle.

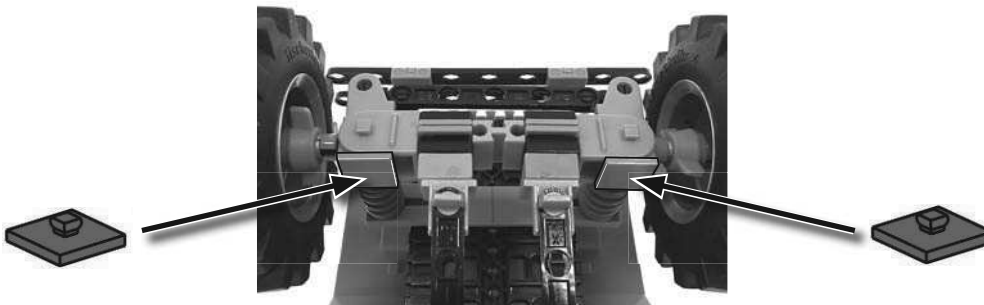

Task 3

Check whether the directional stability of the vehicle has improved by arresting the steering. Does the vehicle remain on track?



Remote Controlled Offroad Vehicle

■ You can install the fischertechnik remote control in your model for even more play fun with your offroad vehicle. The offroad vehicle can easily be equipped with the XM motor set, the Accu Set and the Control Set (not included in construction set).



"Here again I did some research and found out what remote control means. This is based on the discovery of radio waves and thus wireless transfer of signals. One of the first fully functional remote controls was presented by Nikola Tesla in 1898 in New York."

■ The following pictures and explanations show you everything required for a fischertechnik remote control.

The fischertechnik Control Set is an infrared remote control, which operates with invisible light signals instead of radio waves. This 4-channel infrared remote control allows you to control your offroad vehicle. You can control up to three motors and one servo unit. On your model this means infinitely adjustable steering and infinite speed control. In addition to the transmitter, the set includes the receiver and a servo unit for control of the Ackermann steering.

The pullback motor can be replaced by a high power gear motor from the XM Motor Set. In addition to the XM motor, which can also be used for other fischertechnik models, the set includes a number of gears, axles and transmission parts.

The fischertechnik Accu Set is perfect for supplying the power for your remote controlled offroad vehicle. The accu pack can be used longer and recharged again and again. The maximum charging time is two hours.

"I think you could now learn a great deal of technical knowledge about the various types of vehicle drives. Your **fischertechnik trainer** wishes you lots of fun building your models and developing new models you can equip with various drives."

