



<b>Contents</b>	<b>1</b>
<b>History</b>	<b>2</b>
<b>Principles of electronics</b>	<b>2</b>
<b>Electrical circuits</b>	<b>3</b>
<b>Flashlight</b>	<b>3</b>
<b>Continuity tester</b>	<b>4</b>
<b>Refrigerator light</b>	<b>4</b>
<b>Series circuit Punch</b>	<b>5</b>
<b>Parallel circuit</b>	<b>5</b>
<b>Three way switch circuit Hallway light</b>	<b>6</b>
<b>Four way/DPDT switch Merry-go-round</b>	<b>6</b>
<b>Electronic components</b>	<b>7</b>
Resistor	7
Capacitor	7
Light emitting diode	8
Transistor	8
Phototransistor	9
<b>Simple flasher</b>	<b>9</b>
<b>Alternating flasher</b>	<b>9</b>
<b>Touch switch</b>	<b>10</b>
<b>Electronics module</b>	<b>11</b>
<b>Basic program</b>	<b>11</b>
<b>Merry-go-round with electronics module</b>	<b>11</b>
<b>Merry-go-round with light barrier</b>	<b>12</b>
<b>Merry-go-round with touch switch</b>	<b>12</b>
<b>Special programs</b>	<b>13</b>
Ship see-saw	13
Alarm system	13
Ventilating fan	14
Negative temperature coefficient thermistor (NTC)	14
Bathroom fan	14
Sliding door	15
<b>Special programs for digital technology</b>	<b>15</b>
<b>Trouble shooting</b>	<b>15</b>

## Contents



## History



Alessandro Volta

■ The beginnings of electrical/electronic engineering go back to the 17<sup>th</sup> and 18<sup>th</sup> centuries. The basis for scientists in the 19<sup>th</sup> century was established during this period. This allowed Alessandro Volta to develop the voltaic pile, the first functional battery. Philipp Reis invented the telephone in Germany about the same time or perhaps slightly before Alexander Graham Bell in the United States, thus providing a means of voice communication over electrical lines on both continents. In 1879 Thomas Alva Edison turned on the light in the world by inventing the carbon filament light bulb.

Erasmus Kittler established the first course of study in the field of electrical engineering at the technical college in Darmstadt in 1883. In 1884 Heinrich Hertz managed to prove the existence of electromagnetic waves. This was the beginning of wireless radio broadcasting.

Around 1905 J. Ambrose Fleming invented the first vacuum tube for radios. With the aid of the cathode ray tube Manfred von Ardenne built the first electronic television set. A milestone was reached in the field of electronics in 1941 as Konrad Zuse constructed the world's first functional computer.

The era of the vacuum tube came to an end with the invention of the transistor. This allowed many new appliances to be designed very small. In 1958 Jack Kilby developed the first integrated circuit (IC). This development opened the way for today's processor chip technology, thus providing the basis for state-of-the-art computers.

■ The PROFI Electronics construction set deals with the fascinating subject of electrical engineering/electronics. At the beginning you will learn the basic principles of a simple electrical circuit. Moreover you will become familiar with various electronic components such as resistors, capacitors, transistors and photo-transistors. You will learn how to install them in circuits and appliances and how to control them.

## Principles of electronics

■ Where did the term 'Electronics' come from actually? The word 'Electronic' comes from the Greek word 'Elektron'. You can say that it is two words put together; the terms 'Electron' and 'Technology'. Electronics is therefore the technology of electrons.

Electronics can be subdivided into five categories:

- Analog electronics
- Digital electronics
- Logical functions of digital electronics
- High frequency electronics
- Power electronics

Here you will become familiar with three of these areas in detail: Analog and digital electronics and logical functions of digital electronics. Analog electronics deals with changes in physical states in relation to time and value. In analog technology a signal can therefore assume many values over a certain period of time (flashing frequency of a light). Digital electronics deals with processing of signals. In digital electronics only values of '1' and '0' are represented and processed.

■ The logical functions of digital electronics consist of logical elements such as AND, NOR, OR, NAND and NOT gates. Flipflops or counters can store digital signals for further processing. Miniaturization of components on a chip has made it possible to produce highly complex electronic components. One example of this is the use of microprocessors in computers.

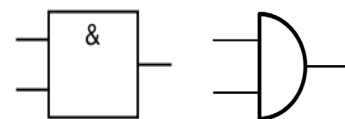

Circuit diagram for an AND gate

Before we start, it will be necessary for you to assemble a few components such as cable, connectors, light bulbs and the 9 V power supply. Exactly what you need to do is described in the assembly instructions under "Assembly Aids and Tips".

After all components are ready for operation, you can learn more about electronics with a couple of simple experiments.

**Power supply:**

Normally you can use the 9V block battery in the battery tray for all your experiments.

Connect a light bulb to the power supply.

Various symbols are used to represent different components in electrical engineering.

## Electrical circuits

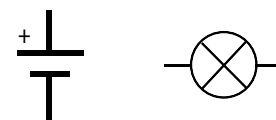

Schematic symbol "Power source"

Schematic symbol "Light"

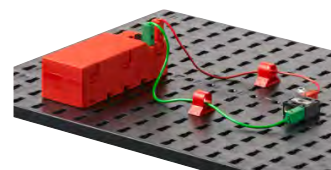

Simple electrical circuit



**Task:**

**What can you observe when the light bulb is connected to the power source?**

The bulb lights up. If you disconnect the cable, the light goes back out.

You have constructed an electrical circuit and the electricity flows in a 'circuit' or 'circle' in the true sense of the word. The electricity flows from the positive pole of the power supply through the red wire to the light bulb and then through the green wire back to the negative pole of the power source. If you interrupt the circuit at any point, for example, by disconnecting a plug, the electric current can no longer flow.

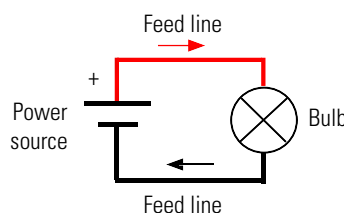

■ In your flashlight model, you use a new component—a push-button switch, also simply called a pushbutton or button. You need this to connect or to interrupt the electric circuit to the light.

Build the flashlight according to the assembly instructions and wire the electrical components according to the circuit diagram. As you can see in the figure below and in the circuit diagram, the pushbutton has various switching positions.

## Flashlight

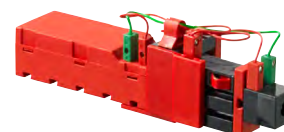

Pushbutton

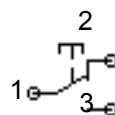

Circuit diagram

**Technical information on pushbutton:**

The pushbutton has three connections or terminals. Depending on the application you can use the pushbutton ....

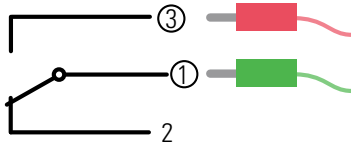

... as a "normally open switch":

By connecting terminals 1 and 3.

When the pushbutton is pressed: Electricity flows.

When the pushbutton is not pressed: Electricity does not flow

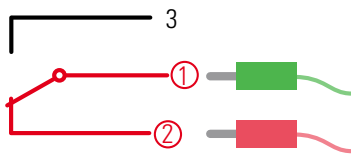

... or as a "normally closed switch":

By connecting terminals 1 and 2.

When the pushbutton is pressed: No electricity flows.

When the pushbutton is not pressed: Electricity flows.



**Task:**

**Does the pushbutton need to operate as a normally closed or normally open switch?**

**Continuity tester**

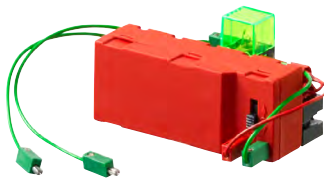

The continuity tester is an important measuring instrument for electricians. This allows the electrician to see if an interruption is present in an electrical circuit or a cable. Construct the continuity tester and wire the electrical components as shown in the circuit diagram.

Do you have any idea how this might work? Then simply get started and try it out. As you can see from the circuit diagram, you need two open contacts, both of which are to be held on the lines to be tested. If the line is okay, current flows and the light provides a visible signal. If the line is defective (interrupted), the light remains off.

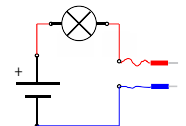

Material	Conductor	Non-conductor
Wood		
Metal		
Paper		

**Task:**

**Test various materials with the model. Which materials conduct the electrical current and which do not?**



**Refrigerator light**

■ Use the pushbutton functions to construct the model of a refrigerator light. Assemble the model and wire the electrical components. How does the refrigerator light work? When you open the door the light on the inside should switch on. When the door is closed again, the interior light should switch back off.

**Task:**

**Consider whether the pushbutton needs to operate as a normally closed or normally open switch for this task.**

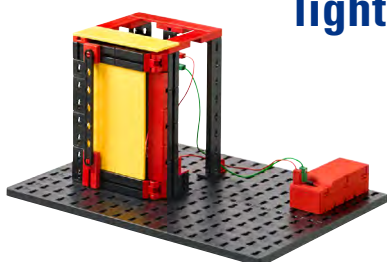

■ The next two experiments will teach you about series and parallel circuits. For this purpose you can construct various models as described in the assembly instructions.

■ A punch is often used to produce sheet metal parts. To ensure that the operator cannot pinch her hand in the machine, it is necessary to press a pushbutton with each hand to start the punching operation. These pushbuttons are connected in series. This is also called an "AND circuit". When T1 AND T2 are pressed, the motor on the punch runs. These switching states can also be represented in a table.

T1	T2	Motor
0	0	0
1	0	0
0	1	0
1	1	1

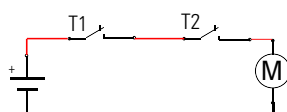

Build the punch to demonstrate a series circuit. For this purpose you will have to use a new part: the motor.

## Series circuit Punch

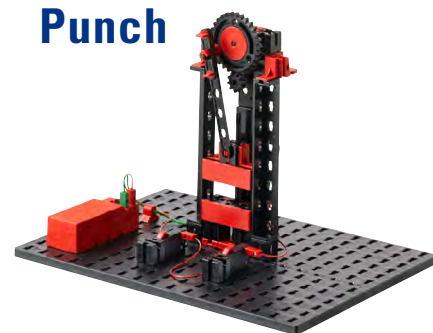

### Task:

Look in the Internet to see how a direct current (DC) motor works. What happens when you reverse the connections (polarity) on the motor?



DC motor

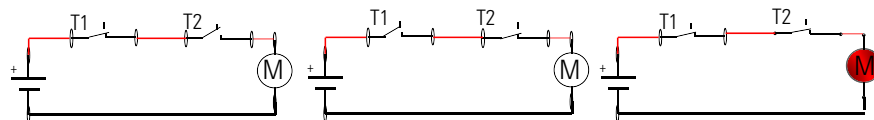

Switching states of T1 and T2 and motor



Circuit symbol

■ Would you like to be able to open the house door from your room or from the intercom? This can be realized with a parallel circuit with two pushbuttons.

This arrangement of the pushbuttons is also known as an "OR circuit". If T1 OR T2 or both pushbuttons are pressed, the door opener is actuated. These switching states can also be represented in a table.

T1	T2	Motor
0	0	0
1	0	1
0	1	1
1	1	1

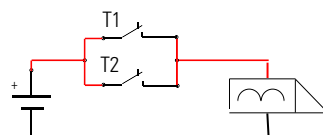

Build the demonstration model of an electric door opener for simulation of a parallel circuit. Replace the door opener with the light bulb from our construction set. The schematic symbol for the door opener is shown in the circuit diagram.

## Parallel circuit

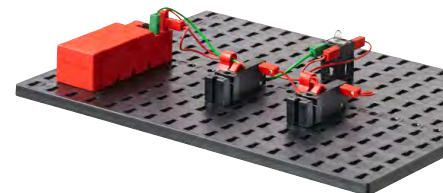

Circuit symbol

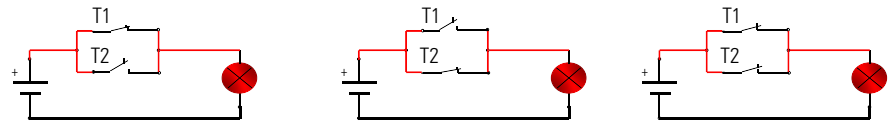

Switching states of T1 and T2 and light

■ A circuit with 2 'three way' or 'single-pole double-throw' (SPDT) switches serves to switch one or more lights from two different locations. It can be used in small hallways, anterooms and rooms with two entrances. You need two pushbuttons from the construction set for this circuit. Construct the model as described in the assembly instructions and wire the circuit.

**Task:**

**What happens when you press a pushbutton (switch) on your model?**

**What happens when you press the second pushbutton (switch)?**



## Three way switch circuit Hallway light

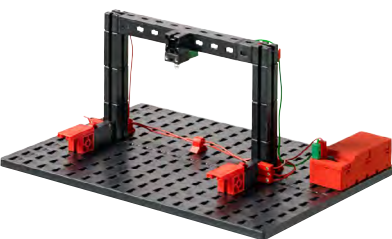
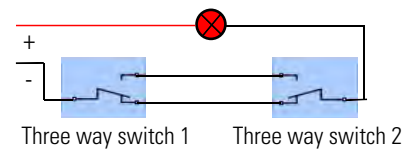
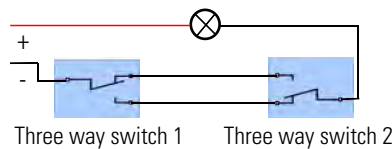
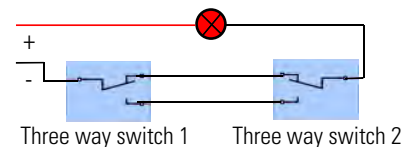
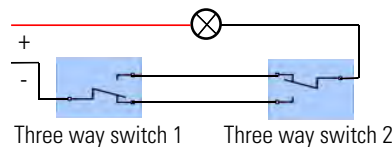
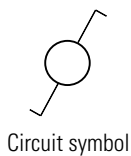
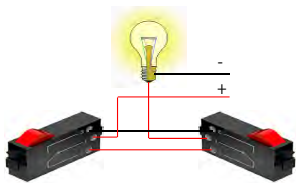

## Four way/DPDT switch Merry-go-round

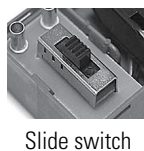
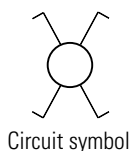

■ You will certainly have already noticed that the battery tray has a switch with three positions. This switch has a number of different names around the world depending on where you live. In the USA electrical engineers call it a 'double-pole double-throw' (DPDT) switch, although it is also commonly called a 'four way' switch. Other names include 'crossover' switch or 'polarity reversing' switch. This switch has four electrical connections. Two of these are always connected. When the switch is 'switched' the connections are reversed. Build the merry-go-round with the aid of the assembly instructions and wire the electrical components as shown in the circuit diagram.

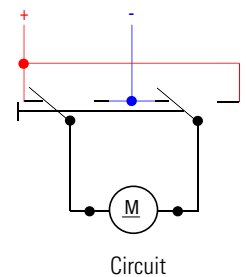

**Task:**

**Try to construct the circuit shown in the diagram for the four way switch with your two pushbuttons and install it directly in your model.**



■ Before starting the electronic experiments, you should become familiar with a few more principles of the electronic components in your construction set.

■ A resistor is a passive component with two poles. Resistors are used to:

- Limit the electrical current to certain values.
- Divide the electrical voltage in a circuit.

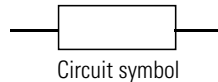

The resistance value is given in Ohms ( $\Omega$ ). The colored rings indicate the resistance value of a resistor.



**Task:**

Use the coding table to determine the values for the two resistors in your construction set.

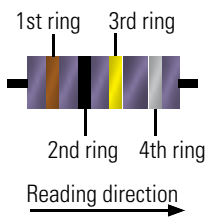

Proceed as follows to read off the value: The distance from the end of the resistor body to the first ring is less than the distance to the last ring or the last ring is offset spatially. According to the table the brown ring stands for 1 and the black ring for 0. Together this results in 10. It is then necessary to multiply this number by the number for the third ring, which is yellow. This results in a value of 100,000  $\Omega$  or 100 k $\Omega$ .

■ A capacitor is an electrical component with the ability to store an electrical charge and therefore the associated energy. It consists of two metal plates (electrodes) of equal size. These are separated from one another by an insulating (dielectric) material. But how does this work? A current flows through a capacitor charging one electrode positive and the other negative. This means that the charge/voltage  $V$  present on the metal plates is stored.

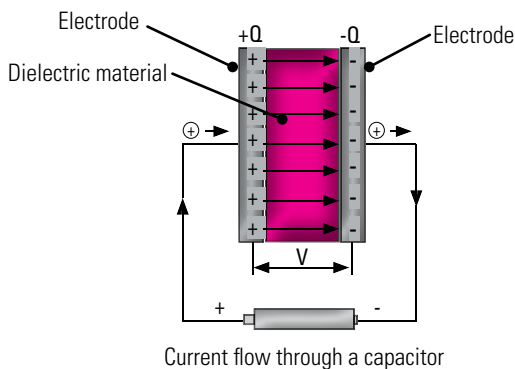

The capacity of a capacitor is given in Farads (F). In the following models the capacitor is used to determine the frequency. In combination with a resistor it is possible to determine the flashing frequency of a light.

## Electronic components

### Resistor



Color	Resistance value in $\Omega$			Tolerance
	1st ring (1st number)	2nd ring (2nd number)	3rd ring (Multiplier)	
"none"	x	—	—	$\pm 20\%$
silver	—	—	$10^{-2} = 0,01$	$\pm 10\%$
gold	—	—	$10^{-1} = 0,1$	$\pm 5\%$
black	—	0	$10^0 = 1$	—
brown	1	1	$10^1 = 10$	$\pm 1\%$
red	2	2	$10^2 = 100$	$\pm 2\%$
orange	3	3	$10^3 = 1,000$	—
yellow	4	4	$10^4 = 10,000$	—
green	5	5	$10^5 = 100,000$	$\pm 0.5\%$
blue	6	6	$10^6 = 1,000,000$	$\pm 0.25\%$
violet	7	7	$10^7 = 10,000,000$	$\pm 0.1\%$
gray	8	8	$10^8 = 100,000,000$	$\pm 0.05\%$
white	9	9	$10^9 = 1,000,000,000$	—

### Capacitor

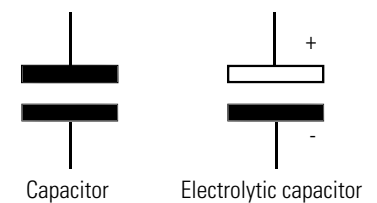

Circuit symbol

## Light emitting diode

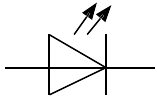

Circuit symbol

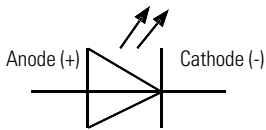

Determination of anode and cathode

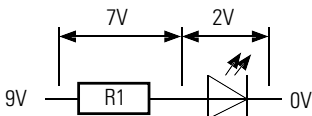

LED with series resistor

■ A light emitting diode is a semiconductor component, which sends out light. The abbreviation is LED from **L**ight **E**mitting **D**iode. When electric current flows through the diode, it sends out, or 'emits' light. The wave length (color of the light) depends on the semi-conductor material and the doping.

The cathode (-) is indicated by a flat spot on the base of the housing. On LEDs the connection for the cathode is shorter.



**Important!** The LEDs used in the construction set are built into a bulb module. Here it is necessary to observe the polarity as described in the assembly instructions.

As a rule the LEDs operate at a voltage of 2V with a current consumption of approx. 20 mA. Your battery supplies a voltage of 9V. For this reason it is necessary to connect a resistor in series to use up the remaining 7V. The size of the resistor can be calculated using Ohm's law.

$$R \text{ (resistance)} = V \text{ (voltage)} / I \text{ (current)} \quad \text{thus } 7 \text{ V} / 0.02 \text{ A} = 350 \Omega$$

**Important!** The LEDs used in your construction set do not require an additional resistor connected in series. This resistor is already built into the LED housing.

## Transistor

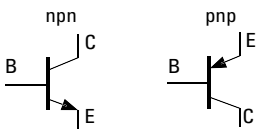

Circuit symbol



■ The transistor, also called a bipolar transistor, is also an electronic component. It is used for switching and amplifying electrical signals. Transistors are the most important constituents in electronic circuits. Transistors have a special significance in integrated circuits. The name transistor was derived from its function. If the resistance of one semi-conductor layer changes, the resistance of the other layer also changes. The concept "transfer resistor" was shortened to "transistor".

A transistor consists of three thin semi-conductor layers on top of one another. We differentiate between

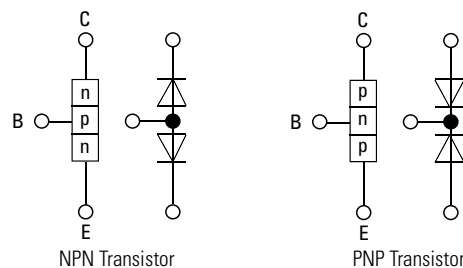

npn and pnp transistors, whereby the letters designate the layer sequence. The middle layer is very thin in comparison to the other two layers. The layers are provided with connections leading out of the housing. The outer layers are called the collector (C) and emitter (E). The middle layer is the base (B). It is the control electrode or the control input for the transistor.



**Task:**

**Find out how a transistor is used and how it works as a switch. A great deal of information on this is available in the Internet.**

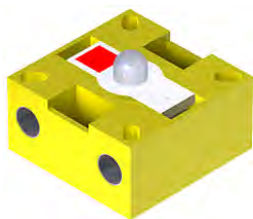

■ In terms of its function a phototransistor is the same as a transistor. Usually it only has two connections leading out—the collector and emitter. Phototransistors are controlled only by the light falling on them (incident light).

**Important!** The phototransistor used in the construction set is built into a bulb module. Here it is necessary to observe the polarity as described in the assembly instructions.

## Phototransistor

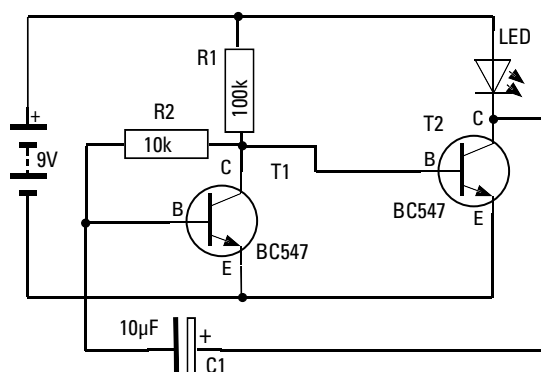
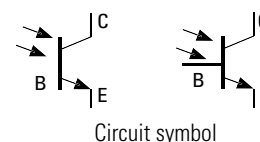

■ Wind power stations and transmitter masts as well radio antenna towers and airplanes have a flashing light to visually signal their position as a safety precaution. Construct the demonstration model of a simple flasher and wire the electrical components as shown in the circuit diagram.

Initially the capacitor is an empty charge storage device. As long as it is being charged, base current cannot flow to T2, so LED1 goes out. When the capacitor has charged up enough, the base current again starts to flow and the light comes back on.

## Simple flasher

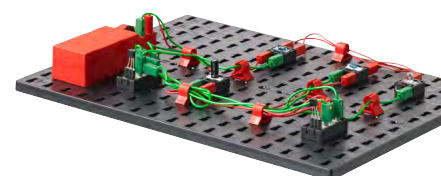

■ "Alternating flasher"—is the name of the next circuit described in the assembly instructions. As you can see from the circuit diagram, there are only three new parts (a capacitor, an LED and a resistor). The resistor and capacitor serve to control LED2.

## Alternating flasher

Replace the 10 kΩ resistor with a 100 kΩ resistor. This circuit is known as an instable flip-flop circuit. In each case the circuit remains in a stable state (meaning one LED continues to burn) until the capacitor has discharged. The circuit then 'flips' to the other state, and the other LED comes on.

**Important!** Ensure that the capacitors are connected with the right polarity.

The flashing frequency of LED1 is determined by capacitor C1 and resistor R1. This can be calculated using the following equation:

$$t = R1 \times C1 \times 1.1$$

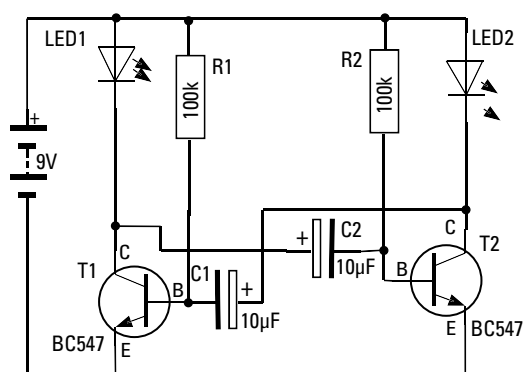

### Task:

Calculate the flashing frequency using the equation. Hint: 1 kΩ corresponds to the number 1000 and 1 µF corresponds to the number 0.000001. Also measure the frequency with a stop watch.



## Touch switch

■ Touch switches are used frequently as switches for opening a door or switching on a light. In technical terminology this switch design is called a "Darlington circuit". Build the circuit as shown in the assembly instructions.

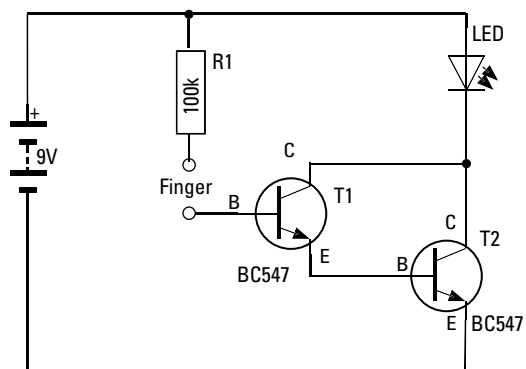
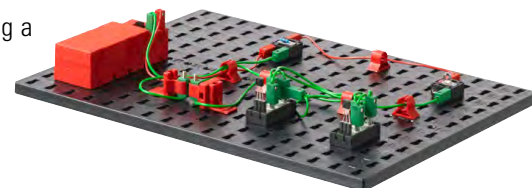

### Task:

**Touch the two bare ends of the connector contacts with two fingers. What happens? What happens when you touch the connector when your fingers are very dry?**



The two transistors increase (amplify) the current causing the LED to illuminate. This amplification is sufficient to obtain an effective touch switch. Why is resistor R1 required? It protects the two transistors from excessive current, which would be present on the base, if the two contacts were connected directly.

### Task:



**Touch only the contact leading to the base of the Darlington circuit and move your feet around on the floor. What happens with the LED?**

The charging effect (static charge) is stronger or weaker depending on the properties of the floor and the material used for your shoe soles. This is visible by the LED flickering.

### Task:

**Replace the LED with a motor. Is it possible for the Darlington circuit to make the motor run?**



■ Your PROFI Electronics construction set also contains an electronics module. This corresponds to a small computer—not nearly as powerful as a PC, but fully sufficient for the following control experiments. You cannot program the electronics module yourself. Various programs are already permanently stored in the module. The five small slide switches allow you to select and run the program required for a particular model.

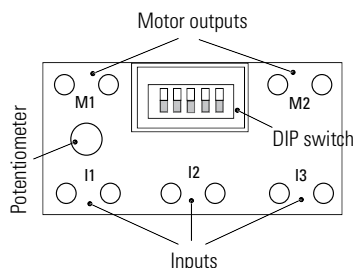

### Power Supply

The electronics module works only when it is connected to a 9V power supply. Use the battery tray with a 9V monobloc battery. When connecting ensure that the polarity is correct (red = positive). When the module is supplied with power correctly, the green LED illuminates.

## Electronics module



#### Inputs I1 - I3:

You can connect the fischertechnik sensors to these inputs. They provide information on the module. The pushbutton, a phototransistor and a heat-sensitive resistor as well as the electronic circuits are available as sensors.

#### Outputs Motor M1 and M2:

You can connect a motor, a light (LED) or an electronic circuit to the outputs. The outputs are switched depending on the program you selected and the state of the inputs.

#### Slide switches (DIP switch) 1-5:

The position of the five slide switches, also known as a DIP switch, determines the function of the electronics module. The desired program can be set with these switches. Here it is necessary to ensure that the DIP switch is in the position required for the particular model. Each switch has two positions: "ON" (up) and "OFF" (down).

When you start your experiments set all DIP switches to "OFF".

DIP1	DIP2	DIP3	DIP4	DIP5
OFF	OFF	OFF	OFF	OFF

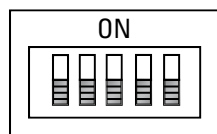

**Important!** The electronics module checks which programs is to be run when the power is switched on. Always set the desired program before connecting to the power supply.

If DIP switch DIP5 is set to "OFF", the so-called basic program is activated. This is a universal program for controlling many models. Use the merry-go-round again for the exercises with the basic program. Connect the electrical components to the electronics module as shown in the assembly instructions.

## Basic program

## Merry-go-round with electronics module

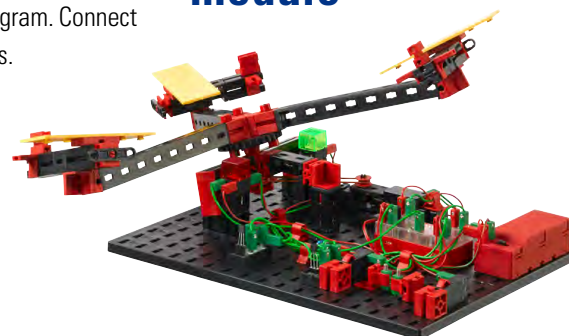

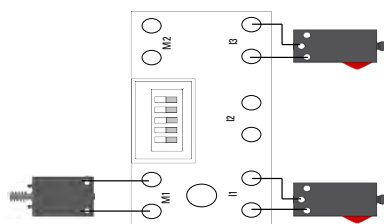

**Task:**  
 Briefly press the pushbutton on I1—the merry-go-round motor starts running.  
 Briefly press the pushbutton on I3—the merry-go-round motor stops.



In the basic program, slide switches 1-4 have special functions:

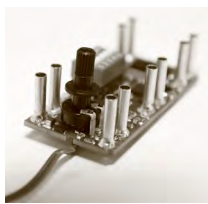

Potentiometers

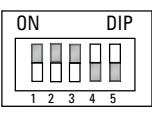

DIP1 - DIP3: Reverse the functions of the inputs. This function is required, for example, when using a light barrier. In this case DIP switches 1-3 must be set to "ON". The input is activated when the light barrier is interrupted.

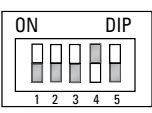

In the basic program, DIP4 (0) allows control of the motor speed using the potentiometer at M1 (a potentiometer is sometimes simply called a 'pot'). This variable resistor is built into your electronics module. When the switch is set to "ON", the flashing frequency can be changed on M2.

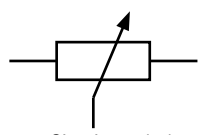

Circuit symbol



**Task:**  
 Use the potentiometer to change the speed of rotation of the motor.

## Merry-go-round with light barrier

Construct the model as shown in the assembly instructions and equip it with a light barrier.

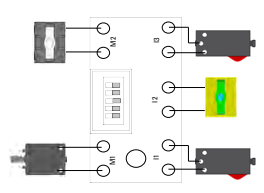

**Task:**  
 Consider how to set DIP2 to change the direction of rotation of the merry-go-round when the light beam is interrupted.



## Merry-go-round with touch switch

Construct the model as shown in the assembly instructions and equip it with the touch switch.

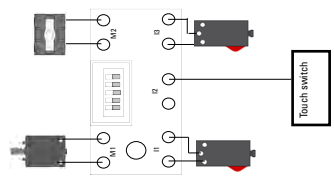

**Task:**  
 Consider how to connect the touch switch to I2 to change the direction of the merry-go-round when it is actuated.



See assembly instructions for circuit diagram.

■ In addition to the basic program, the electronics module also contains other programs laid out especially for various models. To use these programs, it is necessary to set slide switch DIP5 to "ON".

Now DIP1-4 serve for selection of the special programs, instead of coding the pushbuttons and control of the motor or flashing frequency. The description of each model or the table at the end of this activity booklet describe how this coding was defined.

■ The ship see-saw is the first model for you to control with a special program. Construct the model as shown in the assembly instructions and connect the electric components with the electronics module.



Set DIP5 to "ON". This calls the program for control of the ship see-saw.

All of the sensors and actuators you have learned about to date are installed in the ship see-saw model. The slide switch serves for starting the see-saw. When it reaches the push-button switch, the polarity of the motor is reversed causing the see-saw to move back in the other direction until the push-button switch is activated again, reversing the direction. This continues until the slide switch is actuated (opened). The see-saw moves until it interrupts the light beam in the light barrier. In this position the passengers can get in and out. Then the see-saw movement can be started again with the slide switch.

## Special programs



### Ship see-saw



#### Task:

**As a visual highlight, install the two LED in your ship see-saw and control them with your electronic control—the alternating flasher.**

See assembly instructions for circuit diagram.

■ The alarm system is the second model, for which a special program is available. Construct the alarm system as shown in the assembly instructions and connect the electric components to the electronics module.



Set DIP4 to "ON". This calls the program for control of the alarm system.

How does this work? As soon as the door is opened, the red light (LED) starts flashing. When the door is closed, the LED continues to flash. The LED goes out only when another pushbutton (for arming the alarm system) is pressed.

You can construct a real burglar alarm with the special program. With it you can even protect the door to your room to prevent unauthorized access.

### Alarm system

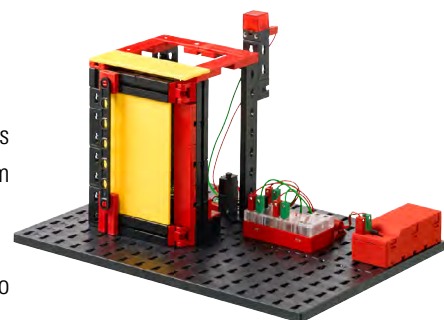

## Ventilating fan

■ It is summer, the sun is shining and a light breeze is blowing. Good that you have a model of a ventilating fan in your construction set.

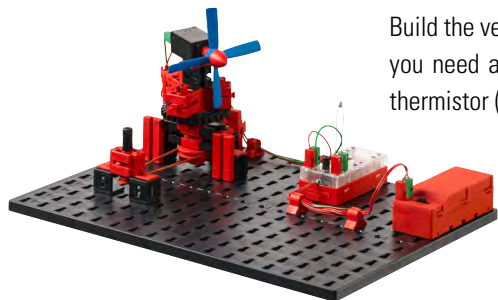

Build the ventilating fan according to the assembly instructions and wire the electrical components. Now you need a new component, which has not yet been explained—the negative temperature coefficient thermistor (NTC).



## Negative temperature coefficient thermistor (NTC)

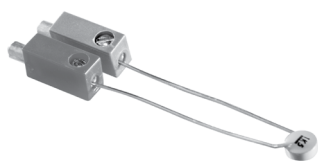

■ Negative temperature coefficient thermistors are semi-conductor resistors, which are temperature-dependent. They have a strong negative temperature coefficient. This is where the name comes from. The resistance value of NTC resistors decreases as the temperature increases, allowing them to conduct electricity better. At decreasing temperature, the resistance increases reducing their conductivity. Since the value of the resistance depends on the temperature, they are not rated. The values can be read off on curves in the data sheets.

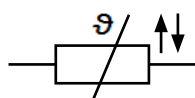

Circuit diagram



Set DIP3 to "ON" and DIP4 to "OFF". This calls the program for control of the ventilating fan.

The fan starts running at a certain temperature, which can be adjusted with the potentiometer. The hotter it gets, the faster the fan runs. By the way, the fan is mounted so it can turn. You can turn it to wherever you want at the moment.

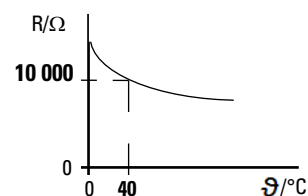

## Bathroom fan

■ If it is not possible to ventilate a bathroom by opening a window, this can be accomplished with a machine. You may be familiar with this from public restrooms, where a fan starts running automatically.

With the fischertechnik bathroom ventilating fan, the fan goes on when the light is switched on. When the light is switched back off, the fan continues to run for a few seconds and then also switches off. The potentiometer allows you to adjust the number of seconds the fan is to continue to run. (0.5sec - 5sec)



Set DIP3 to "ON" and DIP4 to "ON". This calls the program for control of the bathroom fan.

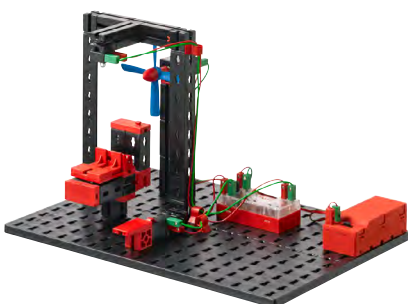

■ Sliding doors are often used in public buildings, as entrances to shops, doctors' offices, etc. The advantage of sliding doors is that they can be opened and closed by light barriers or proximity switches as well as touch switches.

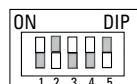

Construct the model as described in the assembly instructions and wire the electrical components.

Set DIP2 to "ON", DIP3 and DIP4 to "OFF". This calls the program for control of the sliding door.

### How does the sliding door work?

When you start the program the door closes. Simultaneously the traffic light turns red. The touch switch makes it possible to open the door again. When the door is open the traffic light switches to green. An internal timer circuit ensures that the door is closed again after a set time. Before this happens the traffic light turns red. The time can be set between 2sec - 5sec on the potentiometer. A safety switch ensures that the door opens again with the built-in light barrier is interrupted. When the light barrier is no longer interrupted, the door closes after a set time.

■ Now that you have learned about all of the models in the construction set, we want to show you some of the other features incorporated into the electronics module. You can certainly use these features to build models using your own ideas. Programs are provided for constructing logical circuits (monoflops, flip-flops, AND and OR gates). Naturally it is even more fun to hook up a number of PROFI electronics modules with one another.

But that would go beyond the scope of this construction set. Information on these features are available in the Internet under "Download" on the fischertechnik homepage [www.fischertechnik.de](http://www.fischertechnik.de)

■ It is always frustrating when you build a model, and it doesn't work like you want. Therefore here are a few tips on how to remedy any problems which might occur.

### Cable and connectors

When assembling connectors ensure you have good contact with the stranded wire. You can test this with the battery and light bulb. You can also use the continuity tester described above.

### Power Supply

If you use the ACCU pack or a battery, ensure enough power is still available. Check this with a light bulb.

### Correct polarity

With some components (capacitors, transistors, phototransistors, LEDs) it is necessary to observe the polarity of the connections. Ensure that the transistor is plugged into the intended socket tightly and the legs make good contact.

### Setting the DIP switch on the electronics module

The DIP switch must be set correctly for the electronics module to execute the correct program. The switch position for each model is shown in the assembly instructions or the activity booklet.

## Sliding door

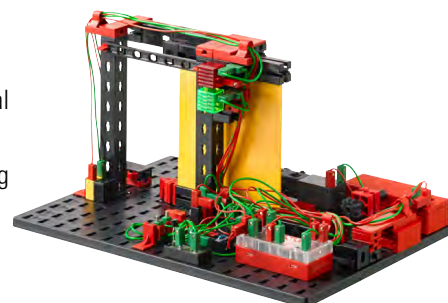

## Special programs for digital technology

## Trouble shooting

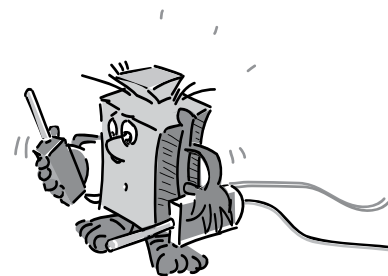

**Important!** The program setting is checked only when the electronics module is switched on.

If you change the program after switching on, it is necessary to momentarily interrupt the power supply to activate the new program.

## DIP switch position

Program	DIP1	DIP2	DIP3	DIP4	DIP5
<b>Basic program</b>					
M1: Motor with function: I1 = Motor counterclockwise I2 = Motor clockwise I3 = Motor stop					0
M1: Motor speed adjustable with potentiometer				0	
M2: Flashing light or motor rotation clockwise/counter-clockwise, frequency 0.5 s					
M1: Constant motor speed				1	
M2: Frequency adjustable on potentiometer from 0.5 s to 5 s					
I1, I2 and I3 as input (normally open contact)	0	0	0		
I1, I2 and I3 as input (normally closed contact)	1	1	1		
<b>Ship see-saw</b>	0	0	0	0	1
<b>Alarm system</b>	0	0	0	1	1
<b>Ventilating fan</b>	0	0	1	0	1
<b>Bathroom fan</b>	0	0	1	1	1
<b>Sliding door</b>	0	1	0	0	1

Legend: 0 = "OFF", 1 = "ON"

Note:

- When the electronics module is restarted in the basic program (DIP 5 "OFF"): When DIP4 is "OFF" -> Flasher 0.5 sec at M2. When DIP4 is "ON" -> Motor set to highest speed at M1.
- When DIP4 is switched when the power to the electronics module is on: The setting on the potentiometer is taken over.
- When DIP5 is switched: Program changes only after restart (switching power off and then back on).

## LED indicator light

LED	Description
LED illuminated continuously	Power supply OK, electronics module ready for operation
LED flashes once	Input to I1, I2 or I3
LED flashes briefly 4 times, pause, flashes briefly 4 times	Short circuit at M1 and/or M2
LED does not illuminate after switching on power supply	Power supply not OK, power supply polarity reversed or electronics module defective (contact fischertechnik service department)

## More intelligent control—fischertechnik ROBOTICS

We hope you have had a lot of fun controlling the models from your PROFI Electronic construction set. Perhaps you can build a few new models yourself and control them with the electronics module. Sooner or later you are bound to come to a point where the basic package is no longer sufficient for really controlling your models and no more special programs are available.

Perhaps a model has several motors and a number of buttons and you want to realize a certain technical sequence. Then you are ready for the next stage in control engineering. The fischertechnik ROBOTICS line.

This line includes a control module, the so-called TXT controller, for controlling four motors simultaneously. It also has eight inputs for buttons, phototransistors or reed contacts. Moreover it has provisions for Bluetooth, WiFi and much more.

